

ANTLR

Latest version is 2.7.3.

Download now! »

DOWNLOAD[Home](#)[Download](#)[News](#)**Using ANTLR**[Documentation](#)[FAQ](#)[Articles](#)[Grammars](#)[File Sharing](#)[Code API](#)[Tech Support](#)**About ANTLR**[What is ANTLR](#)[Why use ANTLR](#)[Showcase](#)[Testimonials](#)[Getting Started](#)[Software License](#)[ANTLR WebLogs](#)[StringTemplate](#)[TML](#)[PCCTS](#)

SEARCH

ANTLR Reference Manual

ANTLR

Reference Manual

Credits

Project Lead and Supreme Dictator

[Terence Parr](#)

University of San Francisco

Support from

[jGuru.com](#)*Your View of the Java Universe*

Help with initial coding

John Lilly, [Empathy Software](#)

C++ code generator by

[Peter Wells](#) and [Ric Klaren](#)

C# code generation by

Micheal Jordan, Kunle Odutola and Anthony Oguntimehin.

Infrastructure support from [Perforce](#):

The world's best source code control system

Substantial intellectual effort donated by

[Loring Craymer](#)[Monty Zukowski](#)[Jim Coker](#)[Scott Stanchfield](#)[John Mitchell](#)[Chapman Flack](#) (UNICODE, streams)

Source changes for Eclipse and NetBeans by

[Marco van Meegen](#) and [Brian Smith](#)

ANTLR Version 2.7.3

March 22, 2004

What's ANTLR

ANTLR, ANOther Tool for Language Recognition, (formerly **PCCTS**) is a language tool that provides a framework for constructing recognizers, compilers, and translators from grammatical descriptions containing Java, C++, or C# actions [You can use PCCTS 1.xx to generate C-based parsers].

Computer language translation has become a common task. While compilers and tools for traditional computer languages (such as C or Java) are still being built, their number is dwarfed by the thousands of mini-languages for which recognizers and translators are being developed. Programmers construct translators for database formats, graphical data files (e.g., PostScript, AutoCAD), text processing files (e.g., HTML, SGML). ANTLR is designed to handle all of your translation tasks.

[Terence Parr](#) has been working on ANTLR since 1989 and, together with his colleagues, has made a number of fundamental [contributions](#) to parsing theory and language tool construction, leading to the resurgence of LL(k)-based recognition tools.

Here is a chronological [history](#) and credit list for ANTLR/PCCTS.

See [ANTLR software rights](#).

Check out [Getting started](#) for a list of tutorials and get your questions answered at the [ANTLR FAQ at jguru.com](#)

See also <http://www.ANTLR.org> and [glossary](#).

If you are looking for the previous main version (PCCTS 1.33) of ANTLR rather than the new Java-based version, see [Getting started with PCCTS](#).

Download [ANTLR](#).

[ANTLR 2.7.3 release notes](#)

[ANTLR Meta-Language](#)

- [Meta-Language Vocabulary](#)
- [Header Section](#)
- [Parser Class Definitions](#)
- [Lexical Analyzer Class Definitions](#)
- [Tree-parser Class Definitions](#)
- [Options Section](#)
- [Tokens Section](#)
- [Grammar Inheritance](#)
- [Rule Definitions](#)
- [Atomic Production elements](#)
- [Simple Production elements](#)
- [Production Element Operators](#)
- [Token Classes](#)
- [Predicates](#)
- [Element Labels](#)
- [EBNF Rule Elements](#)
- [Interpretation Of Semantic Actions](#)
- [Semantic Predicates](#)
- [Syntactic Predicates](#)
 - [Fixed depth lookahead and syntactic predicates](#)
- [ANTLR Meta-Language Grammar](#)

[Lexical Analysis with ANTLR](#)

- [Lexical Rules](#)
 - [Skipping characters](#)
 - [Distinguishing between lexer rules](#)
 - [Return values](#)
- [Predicated-LL\(k\) Lexing](#)
- [Keywords and literals](#)
- [Common prefixes](#)
- [Token definition files](#)
- [Character classes](#)
- [Token Attributes](#)
- [Lexical lookahead and the end-of-token symbol](#)
- [Scanning Binary Files](#)
- [Scanning Unicode Characters](#)
- [Manipulating Token Text and Objects](#)
 - [Manipulating the Text of a Lexical Rule](#)
 - [Heterogeneous Token Object Streams](#)
- [Filtering Input Streams](#)
 - [ANTLR Masquerading as SED](#)
 - [Nongreedy Subrules](#)
 - [Greedy Subrules](#)
 - [Nongreedy Lexer Subrules](#)
 - [Limitations of Nongreedy Subrules](#)
- [Lexical States](#)
- [The End Of File Condition](#)
- [Case sensitivity](#)
- [Ignoring whitespace in the lexer](#)
- [Tracking Line Information](#)
- [Tracking Column Information](#)
- [But...We've Always Used Automata For Lexical Analysis!](#)

[ANTLR Tree Parsers](#)

- [What's a tree parser?](#)
- [What kinds of trees can be parsed?](#)
- [Tree grammar rules](#)
 - [Syntactic predicates](#)
 - [Semantic predicates](#)
 - [An Example Tree Walker](#)
- [Transformations](#)
 - [An Example Tree Transformation](#)
- [Examining/Debugging ASTs](#)

[Token Streams](#)

- [Introduction](#)
- [Pass-Through Token Stream](#)
- [Token Stream Filtering](#)
- [Token Stream Splitting](#)
 - [Example](#)
 - [Filter Implementation](#)
 - [How To Use This Filter](#)
 - [Tree Construction](#)

- [Garbage Collection Issues](#)
 - [Notes](#)
- [Token Stream Multiplexing \(aka "Lexer states"\)](#)
 - [Multiple Lexers](#)
 - [Lexers Sharing Same Character Stream](#)
 - [Parsing Multiplexed Token Streams](#)
 - [The Effect of Lookahead Upon Multiplexed Token Streams](#)
 - [Multiple Lexers Versus Calling Another Lexer Rule](#)
- [TokenStreamRewriteEngine Easy Syntax-Directed Translation](#)
- [The Future](#)

[Token Vocabularies](#)

- [Introduction](#)
 - [How does ANTLR decide which vocabulary symbol gets what token type?](#)
 - [Why do token types start at 4?](#)
 - [What files associated with vocabulary does ANTLR generate?](#)
 - [How does ANTLR synchronize the symbol-type mappings between grammars in the same file and in different files?](#)
- [Grammar Inheritance and Vocabularies](#)
- [Recognizer Generation Order](#)
- [Tricky Vocabulary Stuff](#)

[Error Handling and Recovery](#)

- [ANTLR Exception Hierarchy](#)
- [Modifying Default Error Messages With Paraphrases](#)
- [Parser Exception Handling](#)
- [Specifying Parser Exception-Handlers](#)
- [Default Exception Handling in the Lexer](#)

[Java Runtime Model](#)

- [Programmer's Interface](#)
 - [What ANTLR generates](#)
- [Multiple Lexers/Parsers With Shared Input State](#)
- [Parser Implementation](#)
 - [Parser Class](#)
 - [Parser Methods](#)
 - [EBNF Subrules](#)
 - [Production Prediction](#)
 - [Production Element Recognition](#)
 - [Standard Classes](#)
- [Lexer Implementation](#)
 - [Lexer Form](#)
 - [Creating Your Own Lexer](#)
 - [Lexical Rules](#)
- [Token Objects](#)
- [Token Lookahead Buffer](#)

[C++ Runtime model](#)

- [C++ notes](#)
 - [Building the runtime](#)

- [Getting C++ output](#)
- [Changing the AST Type](#)
- [Using Heterogeneous AST types](#)
- [Extra functionality in C++ mode](#)
- [A grammar template](#)

[C# Runtime model](#)

- [Building the ANTLR C# Runtime](#)
- [Specifying Code Generation](#)
- [C#-Specific ANTLR Options](#)
- [A Template C# ANTLR Grammar File](#)

[ANTLR Tree Construction](#)

- [Notation](#)
- [Controlling AST construction](#)
- [Grammar annotations for building ASTs](#)
 - [Leaf nodes](#)
 - [Root nodes](#)
 - [Turning off standard tree construction](#)
 - [Tree node construction](#)
 - [AST Action Translation](#)
- [Invoking parsers that build trees](#)
- [AST Factories](#)
- [Heterogeneous ASTs](#)
 - [An Expression Tree Example](#)
 - [Describing Heterogeneous Trees With Grammars](#)
- [AST \(XML\) Serialization](#)
- [AST enumerations](#)
- [A few examples](#)
- [Labeled subrules](#)
- [Reference nodes](#)
- [Required AST functionality and form](#)

[Grammar Inheritance](#)

- [Introduction and motivation](#)
- [Functionality](#)
- [Where Are Those Supergrammars?](#)
- [Error Messages](#)

[Options](#)

- [File, Grammar, and Rule Options](#)
 - [Options supported in ANTLR](#)
 - [language: Setting the generated language](#)
 - [k: Setting the lookahead depth](#)
 - [importVocab: Initial Grammar Vocabulary](#)
 - [exportVocab: Naming Output Vocabulary](#)
 - [testLiterals: Generate literal-testing code](#)
 - [defaultErrorHandler: Controlling default exception-handling](#)
 - [codeGenMakeSwitchThreshold: controlling code generation](#)
 - [codeGenBitsetTestThreshold: controlling code generation](#)

- [buildAST: Automatic AST construction](#)
- [ASTLabelType: Setting label type](#)
- [charVocabulary: Setting the lexer character vocabulary](#)
- [warnWhenFollowAmbig](#)
- [Command Line Options](#)

ANTLRLatest version is **2.7.3**.

Download now! »

DOWNLOAD[Home](#)

SEARCH

[Download](#)[News](#)[Using ANTLR](#)

Getting Started with ANTLR

Getting Started with ANTLR

[Documentation](#)[FAQ](#)[Articles](#)[Grammars](#)[File Sharing](#)[Code API](#)[Tech Support](#)[About ANTLR](#)[What is ANTLR](#)[Why use ANTLR](#)[Showcase](#)[Testimonials](#)[Getting Started](#)[Software License](#)[ANTLR WebLogs](#)[StringTemplate](#)[TML](#)[PCCTS](#)

Languages, parsing, and translation are still considered a "black art", but tools like ANTLR can help eliminate some of the mystery and make you very efficient at building translators. Getting started with ANTLR is pretty easy if you start playing around with some existing grammars and read some introductory material. As you progress, you will want to check out more advanced topics and play around by working with bigger grammars. Also please join us on the [antlr-interest mailing list](#) for active discussions on ANTLR and languages.

1. [Download ANTLR 2.7.2](#). First you have to get the software.
2. [Try a cut-n-paste example](#). If you have trouble getting the ANTLR tool to start, read [Why do I get the following Java interpreter error: "Can't find antlr/Tool"?](#).
3. To learn a bit more, read [All I know is that I need to build a parser or translator. Give me an overview of what ANTLR does and how I need to approach building things with ANTLR](#). Here is another description about [parsing simple data](#).
4. To learn about language recognition, you should read the chapter on [Building Translators](#) from the *work in progress* [Practical Computer Language Recognition and Translation book](#).

The following tutorials should also be useful to you:

- [An Introduction To ANTLR](#) (By Terence Parr).
- [Ashley J.S Mills' very thorough tutorial at The University of Birmingham \(Java output\)](#)
- [Dan Bornstein's tutorial \(Java output\)](#)
- [Peter Morling's tutorial \(C++ output\)](#)
- [Sudip Mitra's tutorial](#).
- [John Merrells' BLOG on using ANTLR \(C++\)](#).
- [Scott Stanchfield's tutorial \(Scott's complete compiler\)](#).

That should give you a taste of how to run ANTLR on a simple grammar and some clue about how to build a recognizer and translator. From here, you should start with an [existing grammar](#) that is similar to your intended application and start modifying it. When you run into questions, first examine the output (and source of ANTLR if you want) to see if you can answer your own question. Then you should check the following:

- [The ANTLR FAQ at jGuru](#)
- [The ANTLR Documentation](#)
- [The ANTLR glossary](#)
- [antlr-interest mailing list and other support](#)
- [The ANTLR Forum at jGuru](#)

ANTLR

Latest version is 2.7.3.

Download now! »

DOWNLOAD[Home](#)[Download](#)[News](#)[Using ANTLR](#)[Documentation](#)[FAQ](#)[Articles](#)[Grammars](#)[File Sharing](#)[Code API](#)[Tech Support](#)[About ANTLR](#)[What is ANTLR](#)[Why use ANTLR](#)[Showcase](#)[Testimonials](#)[Getting Started](#)[Software License](#)[ANTLR WebLogs](#)[StringTemplate](#)[TML](#)[PCCTS](#)

SEARCH

ANTLR-centric Language Glossary

ANTLR-centric Language Glossary

Terence Parr

This glossary defines some of the more important terms used in the ANTLR documentation. I have tried to be very informal and provide references to other pages that are useful. For another great source of information about formal computer languages, see [Wikipedia](#).

- [Ambiguous](#)
- [ANTLR](#)
- [AST](#)
- [Bit set](#)
- [Child-sibling Tree](#)
- [Context-free grammar](#)
- [Context-sensitive](#)
- [DFA](#)
- [FIRST](#)
- [FOLLOW](#)
- [Grammar](#)
- [Hoisting](#)
- [Inheritance, grammar](#)
- [LA\(n\)](#)
- [Left-prefix, left factor](#)
- [Literal](#)
- [Linear approximate lookahead](#)
- [LL\(k\)](#)
- [LT\(n\)](#)
- [Language](#)
- [Lexer](#)
- [Lookahead](#)
- [nextToken](#)
- [NFA](#)
- [Nondeterministic](#)
- [Parser](#)
- [Predicate, semantic](#)
- [Predicate, syntactic](#)
- [Production](#)
- [Protected](#)
- [Recursive-descent](#)
- [Regular](#)
- [Rule](#)
- [Scanner](#)
- [Semantics](#)
- [Subrule](#)
- [Syntax](#)

- [Token](#)
- [Token stream](#)
- [Tree](#)
- [Tree parser](#)
- [Vocabulary](#)
- [Wow](#)

Ambiguous

A language is ambiguous if the same sentence or phrase can be interpreted in more than a single way. For example, the following sentence by Groucho Marx is easily interpreted in two ways: "I once shot an elephant in my pajamas. How he got in my pajamas I'll never know!" In the computer world, a typical language ambiguity is the if-then-else ambiguity where the else-clause may be attached to either the most recent if-then or an older one. Reference manuals for computer languages resolve this ambiguity by stating that else-clauses always match up with the most recent if-then.

A grammar is ambiguous if the same input sequence can be derived in multiple ways. Ambiguous languages always yield ambiguous grammars unless you can find a way to encode semantics (actions or predicates etc...) that resolve the ambiguity. Most language tools like ANTLR resolve the if-then-else ambiguity by simply choosing to match greedily (i.e., as soon as possible). This matches the else with the most recent if-then. See nondeterministic.

ANTLR

ANother **T**ool for **L**anguage **R**ecognition, a predicated-LL(k) parser generator that handles lexers, parsers, and tree parsers. ANTLR has been available since 1990 and led to a resurgence of recursive-descent parsing after decades dominated by LR and other DFA-based strategies.

AST

Abstract Syntax Tree. ASTs are used as internal representations of an input stream, normally constructed during a parsing phase. Because AST are two-dimensional trees they can encode the structure (as determined by the parser) of the input as well as the input symbols.

A homogeneous AST is in one in which the physical objects are all of the same type; e.g., `CommonAST` in ANTLR. A heterogeneous tree may have multiple types such as `PlusNode`, `MultiNode` etc...

An AST is not a parse tree, which encodes the sequence of rules used to match input symbols. See [What's the difference between a parse tree and an abstract syntax tree \(AST\)? Why doesn't ANTLR generate trees with nodes for grammar rules like JJTree does?](#).

An AST for input `3+4` might be represented as



or more typically (ala ANTLR) in child-sibling form:



Operators are usually subtree roots and operands are usually leaves.

Bit set

Bit sets are an extremely efficient representation for dense integer sets. You can easily encode sets of strings also by mapping unique strings to unique integers. ANTLR uses bitsets for lookahead prediction in parsers and lexers. Simple bit set implementations do not work so well for sparse sets, particularly when the maximum integer stored in the set is large.

ANTLR's bit set represents membership with a bit for each possible integer value. For a maximum value of n , a bit set needs $n/64$ long words or $n/8$ bytes. For ASCII bit sets with a maximum value of 127, you only need 16 bytes or 2 long words. UNICODE has a max value of `\uFFFF` or 65535, requiring 8k bytes, and these sets are typically sparse. Fortunately most lexers only need a few of these space inefficient (but speedy) bitsets and so it's not really a problem.

Child-sibling Tree

A particularly efficient data structure for representing trees. See AST.

Context-free grammar

A grammar where recognition of a particular construct does not depend on whether it is in a particular syntactic context. A context-free grammar has a set of rules like

```
stat : IF expr THEN stat
      | ...
      ;
```

where there is no restriction on when the `IF` alternative may be applied--if you are in rule `stat`, you may apply the alternative.

Context-sensitive

A grammar where recognition of a particular construct may depend on a syntactic context. You never see these grammars in practice because they are impractical (Note, an Earley parser is $O(n^3)$ worst-case for context-free grammars). A context-free rule looks like:

$$A \rightarrow \gamma$$

but a context-sensitive rule may have context on the left-side:

$$\alpha A \beta \rightarrow \alpha \gamma \beta$$

meaning that rule `A` may only be applied (converted to γ) in between α and β .

In an ANTLR sense, you can recognize context-sensitive constructs with a semantic predicate. The action evaluates to true or false indicating the validity of applying the alternative.

See [Context-sensitive grammar](#).

DFA

Deterministic **F**inite **A**utomata. A state machine used typically to formally describe lexical analyzers. `lex` builds a DFA to recognize tokens whereas ANTLR builds a recursive descent lexer similar to what you would build by hand. See [Finite state machine](#) and ANTLR's lexer documentation.

FIRST

The set of symbols that may be matched on the left-edge of a rule. For example, the `FIRST(decl)` is set

{ID, INT} for the following:

```
decl : ID ID SEMICOLON
      | INT ID SEMICOLON
      ;
```

The situation gets more complicated when you have optional constructs. The FIRST(a) below is {A,B,C}

```
a : (A)? B
    | C
    ;
```

because the A is optional and the B may be seen on the left-edge.

Naturally $k > 1$ lookahead symbols makes this even more complicated. FIRST_k must track sets of k-sequences not just individual symbols.

FOLLOW

The set of input symbols that may follow any reference to the specified rule. For example, FOLLOW(decl) is {RPAREN, SEMICOLON):

```
methodHead : ID LPAREN decl RPAREN ;
var : decl SEMICOLON ;
decl : TYPE_NAME ID ;
```

because RPAREN and SEMICOLON both follow references to rule decl. FIRST and FOLLOW computations are used to analyze grammars and generate parsing decisions.

This grammar analysis all gets very complicated when $k > 1$.

Grammar

A finite means of formally describing the structure of a possibly infinite language. Parser generators build parsers that recognize sentences in the language described by a grammar. Most parser generators allow you to add actions to be executed during the parse.

Hoisting

Semantic predicates describe the semantic context in which a rule or alternative applies. The predicate is hoisted into a prediction expression. Hoisting typically refers to pulling a predicate out of its enclosing rule and into the prediction expression of another rule. For example,

```
decl      : typename ID SEMICOLON
           | ID ID SEMICOLON
           ;
typename : {isType(LT(1))}? ID
           ;
```

The predicate is not needed in typename as there is no decision, however, rule decl needs it to distinguish between its two alternatives. The first alternative would look like:

```
if ( LA(1)==ID && isType(LT(1)) ) {
    typename();
    match(ID);
    match(SEMICOLON);
}
```

PCCTS 1.33 did, but ANTLR currently does not hoist predicates into other rules.

Inheritance, grammar

The ability of ANTLR to define a new grammar as it differs from an existing grammar. See the ANTLR documentation.

LA(n)

The nth lookahead character, token type, or AST node type depending on the grammar type (lexer, parser, or tree parser respectively).

Left-prefix, left factor

A common sequence of symbols on the left-edge of a set of alternatives such as:

```
a : A B X
   | A B Y
   ;
```

The left-prefix is A B, which you can remove by left-factoring:

```
a : A B (X|Y)
   ;
```

Left-factoring is done to reduce lookahead requirements.

Literal

Generally a literal refers to a fixed string such as `begin` that you wish to match. When you reference a literal in an ANTLR grammar via `"begin"`, ANTLR assigns it a token type like any other token. If you have defined a lexer, ANTLR provides information about the literal (type and text) to the lexer so it may detect occurrences of the literal.

Linear approximate lookahead

An approximation to full lookahead (that can be applied to both LL and LR parsers) for $k > 1$ that reduces the complexity of storing and testing lookahead from $O(n^k)$ to $O(nk)$; exponential to linear reduction. When linear approximate lookahead is insufficient (results in a nondeterministic parser), you can use the approximate lookahead to attenuate the cost of building the full decision.

Here is a simple example illustrating the difference between full and approximate lookahead:

```
a : (A B | C D)
   | A D
   ;
```

This rule is LL(2) but not linear approximate LL(2). The real $FIRST_2(a)$ is $\{AB, CD\}$ for alternative 1 and $\{AD\}$ for alternative 2. No intersection, so no problem. Linear approximate lookahead collapses all symbols at depth i yielding k sets instead of a possibly n^k k -sequences. The approximation (compressed) sets are $\{AB, AD, CD, CB\}$ and $\{AD\}$. Note the introduction of the spurious k -sequences AD and CB. Unfortunately, this compression introduces a conflict upon AD between the alternatives. PCCTS did full LL(k) and ANTLR does linear approximate only as I found that linear approximate lookahead works for the vast majority of parsing decisions and is extremely fast. I find one or two problem spots in a large grammar usually with ANTLR, which forces me to reorganize my grammar in a slightly unnatural manner. Unfortunately, your brain does full LL(k) and ANTLR does a slightly weaker

linear approximate lookahead--a source of many (invalid) bug reports ;)

This compression was the subject of [my doctoral dissertation](#) (PDF 477k) at Purdue.

LL(k)

Formally, LL(k) represents a class of parsers and grammars that parse symbols from left-to-right (beginning to end of input stream) using a leftmost derivation and using k symbols of lookahead. A leftmost derivation is one in which derivations (parses) proceed by attempting to replace rule references from left-to-right within a production. Given the following rule

```
stat : IF expr THEN stat
      | ...
      ;
```

an LL parser would match the IF then attempt to parse expr rather than a rightmost derivation, which would attempt to parse stat first.

LL(k) is synonymous with a "top-down" parser because the parser begins at the start symbol and works its way down the derivation/parse tree (tree here means the stack of method activations for recursive descent or symbol stack for a table-driven parser). A recursive-descent parser is particular implementation of an LL parser that uses functions or method calls to implement the parser rather than a table.

ANTLR generates predicate-LL(k) parsers that support syntactic and semantic predicates allowing you to specify many context-free and context-sensitive grammars (with a bit of work).

LT(n)

In a parser, this is the nth lookahead Token object.

Language

A possibly infinite set of valid sentences. The vocabulary symbols may be characters, tokens, and tree nodes in an ANTLR context.

Lexer

A recognizer that breaks up a stream of characters into vocabulary symbols for a parser. The parser pulls vocabulary symbols from the lexer via a queue.

Lookahead

When parsing a stream of input symbols, a parser has matched (and no longer needs to consider) a portion of the stream to the left of its read pointer. The next k symbols to the right of the read pointer are considered the fixed lookahead. This information is used to direct the parser to the next state. In an LL (k) parser this means to predict which path to take from the current state using the next k symbols of lookahead.

ANTLR supports syntactic predicates, a manually-specified form of backtracking that effectively gives you infinite lookahead. For example, consider the following rule that distinguishes between sets (comma-separated lists of words) and parallel assignments (one list assigned to another):

```
stat: ( list "=" )=> list "=" list
      | list
      ;
```

If a list followed by an assignment operator is found on the input stream, the first production is predicted. If not, the second alternative production is attempted.

nextToken

A lexer method automatically generated by ANTLR that figures out which of the lexer rules to apply. For example, if you have two rules ID and INT in your lexer, ANTLR will generate a lexer with methods for ID and INT as well as a nextToken method that figures out which rule method to attempt given k input characters.

NFA

Nondeterministic Finite Automata. See [Finite state machine](#).

Nondeterministic

A parser is nondeterministic if there is at least one decision point where the parser cannot resolve which path to take. Nondeterminisms arise because of parsing strategy weaknesses.

- If your strategy works only for unambiguous grammars, then ambiguous grammars will yield nondeterministic parsers; this is true of the basic LL, LR strategies. Even unambiguous grammars can yield nondeterministic parsers though. Here is a nondeterministic LL(1) grammar:

```
decl : ID ID SEMICOLON
      | ID SEMICOLON
      ;
```

Rule decl is, however, LL(2) because the second lookahead symbol (either ID or SEMICOLON) uniquely determines which alternative to predict. You could also left-factor the rule to reduce the lookahead requirements.

- If you are willing to pay a performance hit or simply need to handle ambiguous grammars, you can use an Earley parser or a Tomita parser (LR-based) that match all possible interpretations of the input, thus, avoiding the idea of nondeterminism altogether. This does present problems when trying to execute actions, however, because multiple parses are, in effect, occurring in parallel.

Note that a parser may have multiple decision points that are nondeterministic.

Parser

A recognizer that applies a grammatical structure to a stream of vocabulary symbols called tokens.

Predicate, semantic

A semantic predicate is a boolean expression used to alter the parse based upon semantic information. This information is usually a function of the constructs/input that have already been matched, but can even be a flag that turns on and off subsets of the language (as you might do for a grammar handling both K&R and ANSI C). One of the most common semantic predicates uses a symbol table to help distinguish between syntactically, but semantically different productions. In FORTRAN, array references and function calls look the same, but may be distinguished by checking what the type of the identifier is.

```
expr : {isVar(LT(1))}? ID LPAREN args RPAREN // array ref
      | {isFunction(LT(1))}? ID LPAREN args RPAREN // func call
      ;
```

Predicate, syntactic

A selective form of backtracking used to recognize language constructs that cannot be distinguished without seeing all or most of the construct. For example, in C++ some declarations look exactly like expressions. You have to check to see if it is a declaration. If it parses like a declaration, assume it is a declaration--reparse it with "feeling" (execute your actions). If not, it must be an expression or an error:

```
stat : (declaration) => declaration
      | expression
      ;
```

Production

An alternative in a grammar rule.

Protected

A protected lexer rule does not represent a complete token--it is a helper rule referenced by another lexer rule. This overloading of the access-visibility Java term occurs because if the rule is not visible, it cannot be "seen" by the parser (yes, this nomenclature sucks).

Recursive-descent

See LL(k).

Regular

A regular language is one that can be described by a regular grammar or regular expression or accepted by a DFA-based lexer such as those generated by `lex`. Regular languages are normally used to describe tokens.

In practice you can pick out a regular grammar by noticing that references to other rules are not allowed except at the end of a production. The following grammar is regular because reference to `B` occurs at the right-edge of rule `A`.

```
A : ('a')+ B ;
B : 'b' ;
```

Another way to look at it is, "what can I recognize without a stack (such as a method return address stack)?"

Regular grammars cannot describe context-free languages, hence, LL or LR based grammars are used to describe programming languages. ANTLR is not restricted to regular languages for tokens because it generates recursive-descent lexers. This makes it handy to recognize HTML tags and so on all in the lexer.

Rule

A rule describes a partial sentence in a language such as a statement or expression in a programming language. Rules may have one or more alternative productions.

Scanner

See Lexer.

Semantics

See [What do "syntax" and "semantics" mean and how are they different?](#).

Subrule

Essentially a rule that has been expanded inline. Subrules are enclosed in parenthesis and may have suffixes like star, plus, and question mark that indicate zero-or-more, one-or-more, or optional. The following rule has 3 subrules:

```
a : (A|B)+ (C)* (D)?  
  ;
```

Syntax

See [What do "syntax" and "semantics" mean and how are they different?](#).

Token

A vocabulary symbol for a language. This term typically refers to the vocabulary symbols of a parser. A token may represent a constant symbol such as a keyword like `begin` or a "class" of input symbols like `ID` or `INTEGER_LITERAL`.

Token stream

See [Token Streams](#) in the ANTLR documentation.

Tree

See AST and [What's the difference between a parse tree and an abstract syntax tree \(AST\)? Why doesn't ANTLR generate trees with nodes for grammar rules like JJTree does?](#).

Tree parser

A recognizer that applies a grammatical structure to a two-dimensional input tree. Grammatical rules are like an "executable comment" that describe the tree structure. These parsers are useful during translation to (i) annotate trees with, for example, symbol table information, (2) perform tree rewrites, and (3) generate output.

Vocabulary

The set of symbols used to construct sentences in a language. These symbols are usually called tokens or token types. For lexers, the vocabulary is a set of characters.

Wow

See ANTLR.

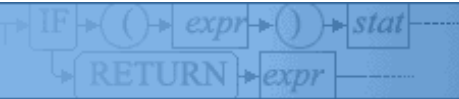
ANTLR

Latest version is 2.7.3.

Download now! »

DOWNLOAD[Home](#)

SEARCH

[Download](#)[News](#)

ANTLR Specification: Meta Language

ANTLR Meta-Language

ANTLR accepts three types of grammar specifications -- parsers, lexers, and tree-parsers (also called tree-walkers). Because ANTLR uses LL(k) analysis for all three grammar variants, the grammar specifications are similar, and the generated lexers and parsers behave similarly. The generated recognizers are human-readable and you can consult the output to clear up many of your questions about ANTLR's behavior.

Meta-Language Vocabulary

Whitespace. Spaces, tabs, and newlines are separators in that they can separate ANTLR vocabulary symbols such as identifiers, but are ignored beyond that. For example, "FirstName LastName" appears as a sequence of two token references to ANTLR not token reference, space, followed by token reference.

Comments. ANTLR accepts C-style block comments and C++-style line comments. Java-style documenting comments are allowed on grammar classes and rules, which are passed to the generated output if requested. For example,

```

/**This grammar recognizes simple expressions
 * @author Terence Parr
 */
class ExprParser;

```

```

/**Match a factor */
factor : ... ;

```

Characters. Character literals are specified just like in Java. They may contain octal-escape characters (e.g., '\377'), Unicode characters (e.g., '\uFF00'), and the usual special character escapes recognized by Java ('\b', '\r', '\t', '\n', '\f', '\\', '\'). In lexer rules, single quotes represent a character to be matched on the input character stream. Single-quoted characters are not supported in parser rules.

End of file. The EOF token is automatically generated for use in parser rules:

```
rule : (statement)+ EOF;
```

You can test for EOF_CHAR in actions of lexer rules:

```

// make sure nothing but newline or
// EOF is past the #endif
ENDIF
{
    boolean eol=false;
}
    :   "#endif"
        ( ('\n' | '\r') {eol=true;} )?
        {

```

[Documentation](#)[FAQ](#)[Articles](#)[Grammars](#)[File Sharing](#)[Code API](#)[Tech Support](#)**About ANTLR**[What is ANTLR](#)[Why use ANTLR](#)[Showcase](#)[Testimonials](#)[Getting Started](#)[Software License](#)[ANTLR WebLogs](#)[StringTemplate](#)[TML](#)[PCCTS](#)

```

        if (!eol) {
            if (LA(1)==EOF_CHAR) {error("EOF");}
            else {error("Invalid chars");}
        }
    }
;

```

While you can test for end-of-file as a character, it is not really a character--it is a condition. You should instead override `CharScanner.uponEOF()`, in your lexer grammar:

```

/** This method is called by YourLexer.nextToken()
 *  when the lexer has
 *  hit EOF condition. EOF is NOT a character.
 *  This method is not called if EOF is reached
 *  during syntactic predicate evaluation or during
 *  evaluation of normal lexical rules, which
 *  presumably would be an IOException. This
 *  traps the "normal" EOF * condition.
 *
 *  uponEOF() is called after the complete evaluation
 *  of the previous token and only if your parser asks
 *  for another token beyond that last non-EOF token.
 *
 *  You might want to throw token or char stream
 *  exceptions like: "Heh, premature eof" or a retry
 *  stream exception ("I found the end of this file,
 *  go back to referencing file").
 */
public void uponEOF()
    throws TokenStreamException, CharStreamException
{
}

```

The end-of-file situation is a bit nutty (since version 2.7.1) because Terence used -1 as a char not an int (-1 is '\uFFFF'...oops).

Strings. String literals are sequences of characters enclosed in double quotes. The characters in the string may be represented using the same escapes (octal, Unicode, etc.) that are valid in character literals. Currently, ANTLR does not actually allow Unicode characters within string literals (you have to use the escape). This is because the `antlr.g` file sets the `charVocabulary` option to `ascii`.

In lexer rules, strings are interpreted as sequences of characters to be matched on the input character stream (e.g., "for" is equivalent to 'f' 'o' 'r').

In parser rules, strings represent tokens, and each unique string is assigned a token type. However, ANTLR does not create lexer rules to match the strings. Instead, ANTLR enters the strings into a literals table in the associated lexer. ANTLR will generate code to test the text of each token against the literals table, and change the token type when a match is encountered before handing the token off to the parser. You may also perform the test manually -- the automatic code-generation is controllable by a [lexer option](#).

You may want to use the token type value of a string literal in your actions, for example in the synchronization part of an error-handler. For string literals that consist of alphabetic characters only, the string literal value will be a constant with a name like `LITERAL_xxx`, where `xxx` is the name of the token. For example, the literal "return" will have an associated value of `LITERAL_return`. You may also assign a specific label to a literal using the `tokens` section.

Token references. Identifiers beginning with an uppercase letter are token references. The subsequent characters may be any letter, digit, or underscore. A token reference in a parser rule results in matching the specified token. A token reference in a lexer rule results in a call to the lexer rule for matching the

characters of the token. In other words, token references in the lexer are treated as rule references.

Token definitions. Token definitions in a lexer have the same syntax as parser rule definitions, but refer to tokens, not parser rules. For example,

```
class MyParser extends Parser;
idList : ( ID )+; // parser rule definition

class MyLexer extends Lexer;
ID : ( 'a'..'z' )+ ; // token definition
```

Rule references. Identifiers beginning with a lowercase letter are references to ANTLR parser rules. The subsequent characters may be any letter, digit, or underscore. Lexical rules may not reference parser rules.

Actions. Character sequences enclosed in (possibly nested) curly braces are semantic actions. Curly braces within string and character literals are not action delimiters.

Arguments Actions. Character sequences in (possibly nested) square brackets are rule argument actions. Square braces within string and character literals are not action delimiters. The arguments within [] are specified using the syntax of the generated language, and should be separated by commas.

```
codeBlock
[int scope, String name] // input arguments
returns [int x]          // return values
: ... ;

// pass 2 args, get return
testcblock
{int y;}
      :      y=cblock[1,"John" ]
      ;
```

Many people would prefer that we use normal parentheses for arguments, but parentheses are best used as grammatical grouping symbols for EBNF.

Symbols. The following table summarizes punctuation and keywords in ANTLR.

Symbol	Description
(...)	subrule
(...)*	closure subrule zero-or-more
(...)+	positive closure subrule one-or-more
(...)?	optional zero-or-one
{ ... }	semantic action
[...]	rule arguments
{ ... }?	semantic predicate
(...)=>	syntactic predicate
	alternative operator
..	range operator

~	not operator
.	wildcard
=	assignment operator
:	label operator, rule start
;	rule end
<...>	element option
class	grammar class
extends	specifies grammar base class
returns	specifies return type of rule
options	options section
tokens	tokens section
header	header section
tokens	token definition section

Header Section

A header section contains source code that must be placed before any ANTLR-generated code in the output parser. This is mainly useful for C++ output due to its requirement that elements be declared before being referenced. In Java, this can be used to specify a package for the resulting parser, and any imported classes. A header section looks like:

```
header {
    source code in the language generated by ANTLR;
}
```

The header section is the first section in a grammar file. Depending on the selected target language more types of header sections might be possible. See the respective addendums.

Parser Class Definitions

All parser rules must be associated with a parser class. A grammar (.g) file may contain only one parser class definitions (along with lexers and tree-parsers). A parser class specification precedes the options and rule definitions of the parser. A parser specification in a grammar file often looks like:

```
{ optional class code preamble }
class YourParserClass extends Parser;
options
tokens
{ optional action for instance vars/methods }
parser rules...
```

When generating code in an object-oriented language, parser classes result in classes in the output, and rules become member methods of the class. In C, classes would result in `structs`, and some name-mangling would be used to make the resulting rule functions globally unique.

The optional class preamble is some arbitrary text enclosed in `{}`. The preamble, if it exists, will be output to the generated class file immediately before the definition of the class.

Enclosing curly braces are not used to delimit the class because it is hard to associate the trailing right curly brace at the bottom of a file with the left curly brace at the top of the file. Instead, a parser class is assumed to continue until the next `class` statement.

You may specify a parser superclass that is used as the superclass for the generate parser. The superclass must be fully-qualified and in double-quotes; it must itself be a subclass of `antlr.LLkParser`. For example,

```
class TinyCParser extends Parser("antlr.debug.ParseTreeDebugParser");
```

Lexical Analyzer Class Definitions

A parser class results in parser objects that know how to apply the associated grammatical structure to an input stream of tokens. To perform lexical analysis, you need to specify a lexer class that describes how to break up the input character stream into a stream of tokens. The syntax is similar to that of a parser class:

```
{ optional class code preamble }
class YourLexerClass extends Lexer;
options
tokens
{ optional action for instance vars/methods }
lexer rules...
```

Lexical rules contained within a lexer class become member methods in the generated class. Each grammar (.g) file may contain only one lexer class. The parser and lexer classes may appear in any order.

The optional class preamble is some arbitrary text enclosed in `{}`. The preamble, if it exists, will be output to the generated class file immediately before the definition of the class.

You may specify a lexer superclass that is used as the superclass for the generate lexer. The superclass must be fully-qualified and in double-quotes; it must itself be a subclass of `antlr.CharScanner`.

Tree-parser Class Definitions

A tree-parser is like a parser, except that it processes a two-dimensional tree of AST nodes instead of a one-dimensional stream of tokens. Tree parsers are specified identically to parsers, except that the rule definitions may contain a [special form](#) to indicate descent into the tree. Again only one tree parser may be specified per grammar (.g) file.

```
{ optional class code preamble }
class YourTreeParserClass extends TreeParser;
options
tokens
{ optional action for instance vars/methods }
tree parser rules...
```

You may specify a tree parser superclass that is used as the superclass for the generate tree parser. The superclass must be fully-qualified and in double-quotes; it must itself be a subclass of `antlr.TreeParser`.

Options Section

Rather than have the programmer specify a bunch of command-line arguments to the parser generator, an [options section](#) within the grammar itself serves this purpose. This solution is preferable because it associates the required options with the grammar rather than ANTLR invocation. The section is

preceded by the `options` keyword and contains a series of option/value assignments. An options section may be specified on both a per-file, per-grammar, per-rule, and per-subrule basis.

You may also specify an option on an element, such as a token reference.

Tokens Section

If you need to define an "imaginary" token, one that has no corresponding real input symbol, use the tokens section to define them. Imaginary tokens are used often for tree nodes that mark or group a subtree resulting from real input. For example, you may decide to have an `EXPR` node be the root of every expression subtree and `DECL` for declaration subtrees for easy reference during tree walking. Because there is no corresponding input symbol for `EXPR`, you cannot reference it in the grammar to implicitly define it. Use the following to define those imaginary tokens.

```
tokens {
    EXPR;
    DECL;
}
```

The formal syntax is:

```
tokenSpec : "tokens" LCURLY
           (tokenItem SEMI)+
           RCURLY
           ;

tokenItem : TOKEN ASSIGN STRING (tokensSpecOptions)?
          | TOKEN (tokensSpecOptions)?
          | STRING (tokensSpecOptions)?
          ;

tokensSpecOptions
: "<"
  id ASSIGN optionValue
  ( SEMI id ASSIGN optionValue )*
">"
;
```

You can also define literals in this section and, most importantly, assign to them a valid label as in the following example.

```
tokens {
    KEYWORD_VOID="void";
    EXPR;
    DECL;
    INT="int";
}
```

Strings defined in this way are treated just as if you had referenced them in the parser.

If a grammar imports a vocabulary containing a token, say T , then you may attach a literal to that token type simply by adding $T="a\ literal"$ to the tokens section of the grammar. Similarly, if the imported vocabulary defines a literal, say `"_int32"`, without a label, you may attach a label via `INT32="_int32"` in the tokens section.

You may define options on the tokens defined in the `tokens` section. The only option available so far is `AST=class-type-to-instantiate`.

```
// Define a bunch of specific AST nodes to build.
// Can override at actual reference of tokens in
// grammar.
tokens {
    PLUS<AST=PLUSNode>;
    STAR<AST=MULTNode>;
}
```

Grammar Inheritance

Object-oriented programming languages such as C++ and Java allow you to define a new object as it differs from an existing object, which provides a number of benefits. "Programming by difference" saves development/testing time and future changes to the *base* or *superclass* are automatically propagated to the *derived* or *subclass*. ANTLR= supports [grammar inheritance](#) as a mechanism for creating a new grammar class based on a base class. Both the grammatical structure and the actions associated with the grammar may be altered independently.

Rule Definitions

Because ANTLR considers lexical analysis to be parsing on a character stream, both lexer and parser rules may be discussed simultaneously. When speaking generically about rules, we will use the term *atom* to mean an element from the input stream (be they characters or tokens).

The structure of an input stream of atoms is specified by a set of mutually-referential rules. Each rule has a name, optionally a set of arguments, optionally a "throws" clause, optionally an init-action, optionally a return value, and an alternative or alternatives. Each alternative contains a series of elements that specify what to match and where.

The basic form of an ANTLR rule is:

```
rulename
    : alternative_1
    | alternative_2
    ...
    | alternative_n
    ;
```

If parameters are required for the rule, use the following form:

```
rulename[formal parameters] : ... ;
```

If you want to return a value from the rule, use the `returns` keyword:

```
rulename returns [type id] : ... ;
```

where *type* is a type specifier of the generated language, and *id* is a valid identifier of the generated language. In Java, a single type identifier would suffice most of the time, but returning an array of strings, for example, would require brackets:

```
ids returns [String[] s]: ( ID {...} )* ;
```

Also, when generating C++, the return type could be complex such as:

```
ids returns [char *[] s]: ... ;
```

The *id* of the `returns` statement is passed to the output code. An action may assign directly to this *id* to set the return value. Do not use a `return` instruction in an action.

To specify that your parser (or tree parser rule) can throw a non-ANTLR specific exception, use the exceptions clause. For example, here is a simple parser specification with a rule that throws `MyException`:

```
class P extends Parser;

a throws MyException
  : A
  ;
```

ANTLR generates the following for rule a:

```
public final void a()
    throws RecognitionException,
           TokenStreamException,
           MyException
{
    try {
        match(A);
    }
    catch (RecognitionException ex) {
        reportError(ex);
        consume();
        consumeUntil(_tokenSet_0);
    }
}
```

Lexer rules may not specify exceptions.

Init-actions are specified before the colon. Init-actions differ from normal actions because they are always executed regardless of guess mode. In addition, they are suitable for local variable definitions.

```
rule
{
    init-action
}
: ...
;
```

Lexer rules. Rules defined within a lexer grammar must have a name beginning with an uppercase letter. These rules implicitly match characters on the input stream instead of tokens on the token stream. Referenced grammar elements include token references (implicit lexer rule references), characters, and strings. Lexer rules are processed in the exact same manner as parser rules and, hence, may specify arguments and return values; further, lexer rules can also have local variables and use recursion. See more about [lexical analysis with ANTLR](#).

Parser rules. Parser rules apply structure to a stream of tokens whereas lexer rules apply structure to a stream of characters. Parser rules, therefore, must not reference character literals. Double-quoted strings in parser rules are considered token references and force ANTLR to squirrel away the string literal into a table that can be checked by actions in the associated lexer.

All parser rules must begin with lowercase letters.

Tree-parser rules. In a tree-parser, an additional special syntax is allowed to specify the match of a two-dimensional structure. Whereas a parser rule may look like:

```
rule : A B C;
```

which means "match A B and C sequentially", a tree-parser rule may also use the syntax:

```
rule : #(A B C);
```

which means "match a node of type A, and then descend into its list of children and match B and C". This notation can be nested arbitrarily, using #(...) anywhere an EBNF construct could be used, for example:

```
rule : #(A B #(C D (E)*) );
```

Atomic Production elements

Character literal. A character literal can only be referred to within a lexer rule. The single character is matched on the character input stream. There are no need to escape regular expression meta symbols because regular expressions are not used to match lexical atoms. For example, '{' need not have an escape as you are specifying the literal character to match. Meta symbols are used outside of characters and string literals to specify lexical structure.

All characters that you reference are implicitly added to the overall character vocabulary (see option `charVocabulary`). The vocabulary comes into play when you reference the wildcard character, '.', or '~c' ("every character but c").

You do not have to treat Unicode character literals specially. Just reference them as you would any other character literal. For example, here is a rule called `LETTER` that matches characters considered Unicode letters:

```
protected
LETTER
    :   '\u0024' |
        '\u0041' .. '\u005a' |
        '\u005f' |
        '\u0061' .. '\u007a' |
        '\u00c0' .. '\u00d6' |
        '\u00d8' .. '\u00f6' |
        '\u00f8' .. '\u00ff' |
        '\u0100' .. '\u1fff' |
        '\u3040' .. '\u318f' |
        '\u3300' .. '\u337f' |
        '\u3400' .. '\u3d2d' |
        '\u4e00' .. '\u9fff' |
        '\uf900' .. '\ufaff'
    ;
```

You can reference this rule from another rule:

```
ID : (LETTER)+
    ;
```

ANTLR will generate code that tests the input characters against a bit set created in the lexer object.

String literal. Referring to a string literal within a parser rule defines a token type for the string literal, and causes the string literal to be placed in a hash table of the associated lexer. The associated lexer will have an automated check against every matched token to see if it matches a literal. If so, the token type for that token is set to the token type for that literal definition imported from the parser. You may turn off the automatic checking and do it yourself in a convenient rule like `ID`. References to string literals within the parser may be suffixed with an element option; see token references below.

Referring to a string within a lexer rule matches the indicated sequence of characters and is a shorthand notation. For example, consider the following lexer rule definition:

```
BEGIN : "begin" ;
```

This rule can be rewritten in a functionally equivalent manner:

```
BEGIN : 'b' 'e' 'g' 'i' 'n' ;
```

There are no need to escape regular expression meta symbols because regular expressions are not used to match characters in the lexer.

Token reference. Referencing a token in a parser rule implies that you want to recognize a token with the specified token type. This does not actually call the associated lexer rule--the lexical analysis phase delivers a stream of tokens to the parser.

A token reference within a lexer rule implies a method call to that rule, and carries the same analysis semantics as a rule reference within a parser. In this situation, you may specify rule arguments and return values. See the next section on rule references.

You may also specify an option on a token reference. Currently, you can only specify the AST node type to create from the token. For example, the following rule instructs ANTLR to build INTNode objects from the INT reference:

```
i : INT<AST=INTNode> ;
```

The syntax of an element option is

```
<option=value; option=value; ...>
```

Wildcard. The "." wildcard within a parser rule matches any single token; within a lexer rule it matches any single character. For example, this matches any single token between the B and C:

```
r : A B . C;
```

Simple Production elements

Rule reference. Referencing a rule implies a method call to that rule at that point in the parse. You may pass parameters and obtain return values. For example, formal and actual parameters are specified within square brackets:

```
funcdef
    :   type ID "(" args ")" block[1]
    ;
block[int scope]
    :   "begin" ... { /*use arg scope/* } "end"
    ;
```

Return values that are stored into variables use a simple assignment notation:

```
set
{ Vector ids=null; } // init-action
:   "(" ids=idList ")"
;
idList returns [Vector strs]
{ strs = new Vector(); } // init-action
:   id:ID
    { strs.appendElement(id.getText()); }
    (
        "," id2:ID
```

```

        { strs.appendElement(id2.getText()); }
    )*
;

```

Semantic action. Actions are blocks of source code (expressed in the target language) enclosed in curly braces. The code is executed after the preceding production element has been recognized and before the recognition of the following element. Actions are typically used to generate output, construct trees, or modify a symbol table. An action's position dictates when it is recognized relative to the surrounding grammar elements.

If the action is the first element of a production, it is executed before any other element in that production, but only if that production is predicted by the lookahead.

The first action of an EBNF subrule may be followed by '!'. Doing so designates the action as an *init-action* and associates it with the subrule as a whole, instead of any production. It is executed immediately upon entering the subrule -- before lookahead prediction for the alternates of the subrule -- and is executed even while guessing (testing syntactic predicates). For example:

```

(   {init-action}:
    {action of 1st production} production_1
|   {action of 2nd production} production_2
)?

```

The init-action would be executed regardless of what (if anything) matched in the optional subrule.

The init-actions are placed within the loops generated for subrules $(\dots)^+$ and $(\dots)^*$.

Production Element Operators

Element complement. The "~" not unary operator must be applied to an atomic element such as a token identifier. For some token atom T , $\sim T$ matches any token other than T except end-of-file. Within lexer rules, $\sim 'a'$ matches any character other than character 'a'. The sequence \sim . ("not anything") is meaningless and not allowed.

The vocabulary space is very important for this operator. In parsers, the complete list of token types is known to ANTLR and, hence, ANTLR simply clones that set and clears the indicated element. For characters, you must specify the character vocabulary if you want to use the complement operator. Note that for large vocabularies like Unicode character blocks, complementing a character means creating a set with 2^{16} elements in the worst case (about 8k). The character vocabulary is the union of characters specified in the `charVocabulary` option and any characters referenced in the lexer rules. Here is a sample use of the character vocabulary option:

```

class L extends Lexer;
options { charVocabulary = '\3'..'377'; } // LATIN

DIGIT : '0'..'9';
SL_COMMENT : "//" (~'\n')* '\n';

```

Set complement. the not operator can also be used to construct a token set or character set by *complementing* another set. This is most useful when you want to match tokens or characters until a certain delimiter set is encountered. Rather than invent a special syntax for such sets, ANTLR allows the placement of \sim in front of a subrule containing only simple elements and no actions. In this specific case, ANTLR will not generate a subrule, and will instead create a set-match. The simple elements may be token references, token ranges, character literals, or character ranges. For example:

```

class P extends Parser;
r : T1 (~ (T1|T2|T3))* (T1|T2|T3);

class L extends Lexer;

```

```
SL_COMMENT : "//" (~('\n' | '\r'))* ('\n' | '\r');
```

```
STRING : '"' (ESC | ~('\\" | '"'))* '"';
```

```
protected ESC : '\\\' ('n' | 'r');
```

Range operator. The range binary operator implies a range of atoms may be matched. The expression 'c1'.. 'c2' in a lexer matches characters inclusively in that range. The expression $T..U$ in a parser matches any token whose token type is inclusively in that range, which is of dubious value unless the token types are generated externally.

AST root operator. When generating abstract syntax trees (ASTs), token references suffixed with the "^" root operator force AST nodes to be created and added as the root of the current tree. This symbol is only effective when the [buildAST option](#) is set. [More information](#) about ASTs is also available.

AST exclude operator. When generating abstract syntax trees, token references suffixed with the "!" exclude operator are not included in the AST constructed for that rule. Rule references can also be suffixed with the exclude operator, which implies that, while the tree for the referenced rule is constructed, it is not linked into the tree for the referencing rule. This symbol is only effective when the [buildAST option](#) is set. [More information](#) about ASTs is also available.

Token Classes

By using a range operator, a not operator, or a subrule with purely atomic elements, you implicitly define an "anonymous" token or character class--a set that is very efficient in time and space. For example, you can define a lexer rule such as:

```
OPS : (PLUS | MINUS | MULT | DIV) ;
```

or

```
WS : (' ' | '\n' | '\t') ;
```

These describe sets of tokens and characters respectively that are easily optimized to simple, single, bit-sets rather than series of token and character comparisons.

Predicates

Semantic predicate. Semantics predicates are conditions that must be met at parse-time before parsing can continue past them. The functionality of [semantic predicates](#) is explained in more detail later. The syntax of a semantic predicate is a semantic action suffixed by a question operator:

```
{ expression }?
```

The expression must not have side-effects and must evaluate to true or false (`boolean` in Java or `bool` in C++). Since semantic predicates can be executed while guessing, they should not rely upon the results of actions or rule parameters.

Syntactic predicate. Syntactic predicates specify the lookahead language needed to predict an alternative. [Syntactic predicates](#) are explained in more detail later. The syntax of a syntactic predicate is a subrule with a => operator suffix:

```
( lookahead-language ) => production
```

Where the lookahead-language can be any valid ANTLR construct including references to other rules. Actions are not executed, however, during the evaluation of a syntactic predicate.

Element Labels

Any atomic or rule reference production element can be labeled with an identifier (case not significant). In the case of a labeled atomic element, the identifier is used within a semantic action to access the associated `Token` object or character. For example,

```
assign
  :  v:ID "=" expr ";"
    { System.out.println(
      "assign to "+v.getText()); }
  ;
```

No "\$" operator is needed to reference the label from within an action as was the case with PCCTS 1.xx.

Inside actions a token reference can be accessed as `label` to access the `Token` object, or as `#label` to access the AST generated for the token. The AST node constructed for a rule reference may be accessed from within actions as `#label`.

Labels on token references can also be used in association with parser [exception handlers](#) to specify what happens when that token cannot be matched.

Labels on rule references are used for [parser exception handling](#) so that any exceptions generated while executing the labeled rule can be caught.

EBNF Rule Elements

ANTLR supports extended BNF notation according to the following four subrule syntax / syntax diagrams:

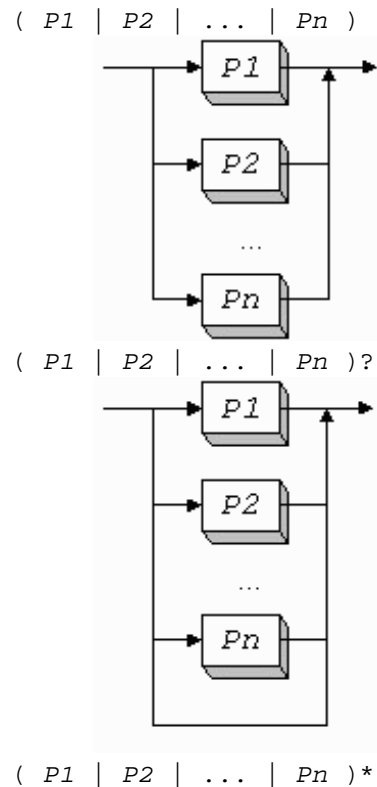

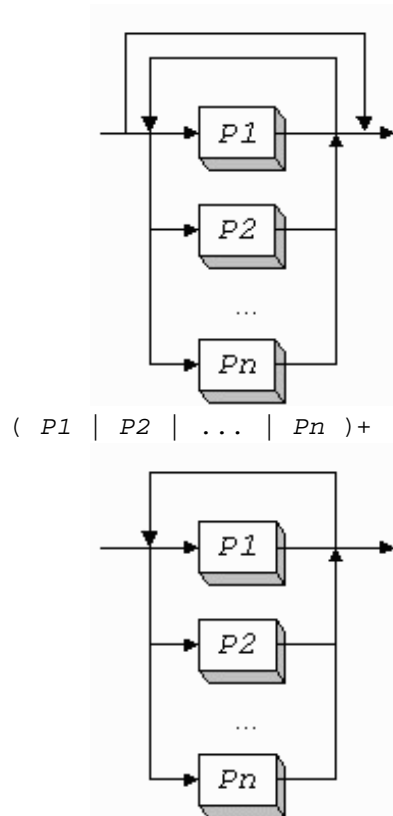

Interpretation Of Semantic Actions

Semantic actions are copied to the appropriate position in the output parser verbatim with the exception of [AST action translation](#).

None of the \$-variable notation from PCCTS 1.xx carries forward into ANTLR.

Semantic Predicates

A semantic predicate specifies a condition that must be met (at run-time) before parsing may proceed. We differentiate between two types of semantic predicates: (i) *validating* predicates that throw exceptions if their conditions are not met while parsing a production (like assertions) and (ii) *disambiguating* predicates that are *hoisted* into the prediction expression for the associated production.

Semantic predicates are syntactically semantic actions suffixed with a question mark operator:

```
{ semantic-predicate-expression }?
```

The expression may use any symbol provided by the programmer or generated by ANTLR that is visible at the point in the output the expression appears.

The position of a predicate within a production determines which type of predicate it is. For example, consider the following validating predicate (which appear at any non-left-edge position) that ensures an identifier is semantically a type name:

```
decl: "var" ID ":" t:ID
      { isTypeName(t.getText()) }?
      ;
```

Validating predicates generate parser exceptions when they fail. The thrown exception is of type `SemanticException`. You can catch this and other parser exceptions in an [exception handler](#).

Disambiguating predicates are always the first element in a production because they cannot be hoisted over actions, token, or rule references. For example, the first production of the following rule has a disambiguating predicate that would be hoisted into the prediction expression for the first alternative:

```
stat:    // declaration "type varName;"
        {isTypeName(LT(1))}? ID ID ";"
      |   ID "=" expr ";"           // assignment
      ;
```

If we restrict this grammar to LL(1), it is syntactically nondeterministic because of the common left-prefix: ID. However, the semantic predicate correctly provides additional information that disambiguates the parsing decision. The parsing logic would be:

```
if ( LA(1)==ID && isTypeName(LT(1)) ) {
    match production one
}
else if ( LA(1)==ID ) {
    match production one
}
else error
```

Formally, in PCCTS 1.xx, semantic predicates represented the semantic context of a production. As such, the semantic AND syntactic context (lookahead) could be hoisted into other rules. In ANTLR, predicates are not hoisted outside of their enclosing rule. Consequently, rules such as:

```
type : {isType(t)}? ID ;
```

are meaningless. On the other hand, this "semantic context" feature caused considerable confusion to many PCCTS 1.xx folks.

Syntactic Predicates

There are occasionally parsing decisions that cannot be rendered deterministic with finite lookahead. For example:

```
a   :   ( A )+ B
      |   ( A )+ C
      ;
```

The common left-prefix renders these two productions nondeterministic in the LL(k) sense for any value of k. Clearly, these two productions can be *left-factored* into:

```
a   :   ( A )+ ( B|C)
      ;
```

without changing the recognized language. However, when actions are embedded in grammars, left-factoring is not always possible. Further, left-factoring and other grammatical manipulations do not result in natural (readable) grammars.

The solution is simply to use arbitrary lookahead in the few cases where finite LL(k) for k>1 is insufficient. ANTLR allows you to specify a lookahead language with possibly infinite strings using the following syntax:

```
( prediction block ) => production
```

For example, consider the following rule that distinguishes between sets (comma-separated lists of words) and parallel assignments (one list assigned to another):

```

stat:  ( list "=" )=> list "=" list
      |  list
      ;

```

If a `list` followed by an assignment operator is found on the input stream, the first production is predicted. If not, the second alternative production is attempted.

Syntactic predicates are a form of selective backtracking and, therefore, actions are turned off while evaluating a syntactic predicate so that actions do not have to be undone.

Syntactic predicates are implemented using exceptions in the target language if they exist. When generating C code, `longjmp` would have to be used.

We could have chosen to simply use arbitrary lookahead for any non-LL(k) decision found in a grammar. However, making the arbitrary lookahead explicit in the grammar is useful because you don't have to guess what the parser will be doing. Most importantly, there are language constructs that are ambiguous for which there exists no deterministic grammar! For example, the infamous if-then-else construct has no LL(k) grammar for any k. The following grammar is ambiguous and, hence, nondeterministic:

```

stat:  "if" expr "then" stat ( "else" stat )?
      |  ...
      ;

```

Given a choice between two productions in a nondeterministic decision, we simply choose the first one. This works out well in most situations. Forcing this decision to use arbitrary lookahead would simply slow the parse down.

Fixed depth lookahead and syntactic predicates

ANTLR cannot be sure what lookahead can follow a syntactic predicate (the only logical possibility is whatever follows the alternative predicted by the predicate, but erroneous input and so on complicates this), hence, ANTLR assumes anything can follow. This situation is similar to the computation of lexical lookahead when it hits the end of the token rule definition.

Consider a predicate with a `(...)*` whose implicit exit branch forces a computation attempt on what follows the loop, which is the end of the syntactic predicate in this case.

```

class parse extends Parser;
a      :      (A (P)*) => A (P)*
      |      A
      ;

```

The lookahead is artificially set to "any token" for the exit branch. Normally, the P and the "any token" would conflict, but ANTLR knows that what you mean is to match a bunch of P tokens if they are present--no warning is generated.

If more than one path can lead to the end of the predicate in any one decision, ANTLR will generate a warning. The following rule results in two warnings.

```

class parse extends Parser;
a      :      (A (P|)*) => A (P)*
      |      A
      ;

```

The empty alternative can indirectly be the start of the loop and, hence, conflicts with the P. Further, ANTLR detects the problem that two paths reach end of predicate. The resulting parser will compile but never terminate the `(P|)*` loop.

The situation is complicated by $k > 1$ lookahead. When the n th lookahead depth reaches the end of the predicate, it records the fact and then code generation ignores the lookahead for that depth.

```
class parse extends Parser;
options {
    k=2;
}
a      :      (A (P B|P )*) => A (P)*
      |      A
      ;
```

ANTLR generates a decision of the following form inside the $(..)^*$ of the predicate:

```
if ((LA(1)==P) && (LA(2)==B)) {
    match(P);
    match(B);
}
else if ((LA(1)==P) && (true)) {
    match(P);
}
else {
    break _loop4;
}
```

This computation works in all grammar types.

ANTLR Meta-Language Grammar

See `antlr/antlr.g` for the grammar that describes ANTLR input grammar syntax in ANTLR meta-language itself.

Version: \$Id: //depot/code/org.antlr/release/antlr-2.7.3/doc/metalang.html#2 \$



Latest version is 2.7.3.

Download now! »

DOWNLOAD[Home](#)

SEARCH

[Download](#)[News](#)

Lexical Analysis with ANTLR

[Using ANTLR](#)

Lexical Analysis with ANTLR

[Documentation](#)[FAQ](#)[Articles](#)[Grammars](#)[File Sharing](#)[Code API](#)[Tech Support](#)

A *lexer* (often called a scanner) breaks up an input stream of characters into vocabulary symbols for a parser, which applies a grammatical structure to that symbol stream. Because ANTLR employs the same recognition mechanism for lexing, parsing, and tree parsing, ANTLR-generated lexers are much stronger than DFA-based lexers such as those generated by DLG (from PCCTS 1.33) and lex.

The increase in lexing power comes at the cost of some inconvenience in lexer specification and indeed requires a serious shift your thoughts about lexical analysis. See a [comparison of LL\(k\) and DFA-based lexical analysis](#).

[About ANTLR](#)

ANTLR generates predicated-LL(k) lexers, which means that you can have semantic and syntactic predicates and use k>1 lookahead. The other advantages are:

[What is ANTLR](#)

- You can actually read and debug the output as its very similar to what you would build by hand.
- The syntax for specifying lexical structure is the same for lexers, parsers, and tree parsers.
- You can have actions executed during the recognition of a single token.
- You can recognize complicated tokens such as HTML tags or "executable" comments like the javadoc @-tags inside `/** ... */` comments. The lexer has a stack, unlike a DFA, so you can match nested structures such as nested comments.

[Why use ANTLR](#)[Showcase](#)[Testimonials](#)[Getting Started](#)[Software License](#)[ANTLR WebLogs](#)

The overall structure of a lexer is:

[StringTemplate](#)

```

class MyLexer extends Lexer;
options {
    some options
}
{
    lexer class members
}
lexical rules
  
```

[TML](#)[PCCTS](#)

Lexical Rules

Rules defined within a lexer grammar must have a name beginning with an uppercase letter. These rules implicitly match characters on the input stream instead of tokens on the token stream. Referenced grammar elements include token references (implicit lexer rule references), characters, and strings. Lexer rules are processed in the exact same manner as parser rules and, hence, may specify arguments and return values; further, lexer rules can also have local variables and use recursion. The following rule defines a rule called `ID` that is available as a token type in the parser.

```

ID : ( 'a'..'z' )+
    ;
  
```

This rule would become part of the resulting lexer and would appear as a method called `mID()` that looks sort of like this:

```

public final void mID(...)
  
```

```

        throws RecognitionException,
                CharStreamException, TokenStreamException
    {
        ...
        _loop3:
        do {
            if (((LA(1) >= 'a' && LA(1) <= 'z'))) {
                matchRange('a','z');
            }
        } while (...);
        ...
    }

```

It is a good idea to become familiar with ANTLR's output--the generated lexers are human-readable and make a lot of concepts more transparent.

Skipping characters

To have the characters matched by a rule ignored, set the token type to `Token.SKIP`. For example,

```

WS : ( ' ' | '\t' | '\n' { newline(); } | '\r' )+
    { setType(Token.SKIP); }
;

```

Skipped tokens force the lexer to reset and try for another token. Skipped tokens are never sent back to the parser.

Distinguishing between lexer rules

As with most lexer generators like `lex`, you simply list a set of lexical rules that match tokens. The tool then automatically generates code to map the next input character(s) to a rule likely to match. Because ANTLR generates recursive-descent lexers just like it does for parsers and tree parsers, ANTLR automatically generates a method for a fictitious rule called `nextToken` that predicts which of your lexer rules will match upon seeing the character lookahead. You can think of this method as just a big "switch" that routes recognition flow to the appropriate rule (the code may be much more complicated than a simple `switch`-statement, however). Method `nextToken` is the only method of `TokenStream` (in Java):

```

public interface TokenStream {
    public Token nextToken() throws TokenStreamException;
}

```

A parser feeds off a lookahead buffer and the buffer pulls from any `TokenStream`. Consider the following two ANTLR lexer rules:

```

INT : ('0'..'9')+;
WS : ' ' | '\t' | '\r' | '\n';

```

You will see something like the following method in lexer generated by ANTLR:

```

public Token nextToken() throws TokenStreamException {
    ...
    for (;;) {
        Token _token = null;
        int _ttype = Token.INVALID_TYPE;
        resetText();
        ...
        switch (LA(1)) {
            case '0': case '1': case '2': case '3':

```

```

        case '4': case '5': case '6': case '7':
        case '8': case '9':
            mINT(); break;
        case '\t': case '\n': case '\r': case ' ':
            mWS(); break;
        default: // error
    }
    ...
}
}

```

What happens when the same character predicts more than a single lexical rule? ANTLR generates a nondeterminism warning between the offending rules, indicating you need to make sure your rules do not have common left-prefixes. ANTLR does not follow the common lexer rule of "first definition wins" (the alternatives within a rule, however, still follow this rule). Instead, sufficient power is given to handle the two most common cases of ambiguity, namely "keywords vs. identifiers", and "common prefixes"; and for especially nasty cases you can use syntactic or semantic predicates.

What if you want to break up the definition of a complicated rule into multiple rules? Surely you don't want every rule to result in a complete Token object in this case. Some rules are only around to help other rules construct tokens. To distinguish these "helper" rules from rules that result in tokens, use the `protected` modifier. This overloading of the access-visibility Java term occurs because if the rule is not visible, it cannot be "seen" by the parser (yes, this nomenclature sucks). See also [What is a "protected" lexer rule.](#)

Another, more practical, way to look at this is to note that only non-protected rules get called by `nextToken` and, hence, only non-protected rules can generate tokens that get shoved down the `TokenStream` pipe to the parser.

Return values

All rules return a token object (conceptually) automatically, which contains the text matched for the rule and its token type at least. To specify a user-defined return value, define a return value and set it in an action:

```

protected
INT returns [int v]
    : ('0'..'9')+ { v=Integer.valueOf($getText); }
;

```

Note that only protected rules can have a return type since regular lexer rules generally are invoked by `nextToken()` and the parser cannot access the return value, leading to confusion.

Predicated-LL(k) Lexing

Lexer rules allow your parser to match *context-free* structures on the input character stream as opposed to the much weaker *regular* structures (using a DFA--deterministic finite automaton). For example, consider that matching nested curly braces with a DFA must be done using a counter whereas nested curlies are trivially matched with a context-free grammar:

```

ACTION
    : '{' ( ACTION | ~'}' )* '}'
;

```

The recursion from rule ACTION to ACTION, of course, is the dead giveaway that this is not an ordinary lexer rule.

Because the same algorithms are used to analyze lexer and parser rules, lexer rules may use more than

a single symbol of lookahead, can use semantic predicates, and can specify syntactic predicates to look arbitrarily ahead, thus, providing recognition capabilities beyond the LL(k) languages into the *context-sensitive*. Here is a simple example that requires $k > 1$ lookahead:

```
ESCAPE_CHAR
    :   '\\\ ' 't' // two char of lookahead needed,
    |   '\\\ ' 'n' // due to common left-prefix
    ;
```

To illustrate the use of syntactic predicates for lexer rules, consider the problem of distinguishing between floating point numbers and ranges in Pascal. Input 3 . . 4 must be broken up into 3 tokens: INT, RANGE, followed by INT. Input 3 . 4, on the other hand, must be sent to the parser as a REAL. The trouble is that the series of digits before the first ' . ' can be arbitrarily long. The scanner then must consume the first ' . ' to see if the next character is a ' . ', which would imply that it must back up and consider the first series of digits an integer. Using a non-backtracking lexer makes this task very difficult; without backtracking, your lexer has to be able to respond with more than a single token at one time. However, a syntactic predicate can be used to specify what arbitrary lookahead is necessary:

```
class Pascal extends Parser;

prog:   INT
        (   RANGE INT
            { System.out.println("INT .. INT"); }
        |   EOF
            { System.out.println("plain old INT"); }
        )
    |   REAL { System.out.println("token REAL"); }
    ;

class LexPascal extends Lexer;

WS   :   ( ' '
        |   '\t'
        |   '\n'
        |   '\r' )+
        { $setType(Token.SKIP); }
    ;

protected
INT  :   ('0'..'9')+
    ;

protected
REAL:   INT '.' INT
    ;

RANGE
    :   ".."
    ;

RANGE_OR_INT
    :   ( INT ".." ) => INT { $setType(INT); }
    |   ( INT '.' )  => REAL { $setType(REAL); }
    |   INT
        { $setType(INT); }
    ;
```

ANTLR lexer rules are even able to handle FORTRAN assignments and other difficult lexical constructs. Consider the following DO loop:

```
DO 100 I = 1,10
```

If the comma were replaced with a period, the loop would become an assignment to a weird variable called "DO100I":

```
DO 100 I = 1.10
```

The following rules correctly differentiate the two cases:

```
DO_OR_VAR
  :   (DO_HEADER)=> "DO" { $setType(DO); }
  |   VARIABLE { $setType(VARIABLE); }
  ;

protected
DO_HEADER
options { ignore=WS; }
  :   "DO" INT VARIABLE '=' EXPR ','
  ;

protected INT : ('0'..'9')+;

protected WS : ' ';

protected
VARIABLE
  :   'A'..'Z'
      ('A'..'Z' | ' ' | '0'..'9')*
      { /* strip space from end */ }
  ;

// just an int or float
protected EXPR
  :   INT ( '.' (INT)? )?
  ;
```

The previous examples discuss differentiating lexical rules via lots of lookahead (fixed k or arbitrary). There are other situations where you have to turn on and off certain lexical rules (making certain tokens valid and invalid) depending on prior context or semantic information. One of the best examples is matching a token only if it starts on the left edge of a line (i.e., column 1). Without being able to test the state of the lexer's column counter, you cannot do a decent job. Here is a simple `DEFINE` rule that is only matched if the semantic predicate is true.

```
DEFINE
  :   {getColumn()==1}? "#define" ID
  ;
```

Semantic predicates on the **left-edge** of **single-alternative** lexical rules get hoisted into the `nextToken` prediction mechanism. Adding the predicate to a rule makes it so that it is not a candidate for recognition until the predicate evaluates to true. In this case, the method for `DEFINE` would never be entered, even if the lookahead predicted `#define`, if the column > 1 .

Another useful example involves context-sensitive recognition such as when you want to match a token only if your lexer is in a particular context (e.g., the lexer previously matched some trigger sequence). If you are matching tokens that separate rows of data such as "----", you probably only want to match this if the "begin table" sequence has been found.

```
BEGIN_TABLE
  :   '[' {this.inTable=true;} // enter table context
  ;

ROW_SEP
```

```

        :   {this.inTable}? "----"
        ;

END_TABLE
    :   ']' {this.inTable=false;} // exit table context
    ;

```

This predicate hoisting ability is another way to simulate lexical states from DFA-based lexer generators like `lex`, though predicates are much more powerful. (You could even turn on certain rules according to the phase of the moon). ;)

Keywords and literals

Many languages have a general "identifier" lexical rule, and keywords that are special cases of the identifier pattern. A typical identifier token is defined as:

```
ID : LETTER (LETTER | DIGIT)*;
```

This is often in conflict with keywords. ANTLR solves this problem by letting you put fixed keywords into a literals table. The literals table (which is usually implemented as a hash table in the lexer) is checked after each token is matched, so that the literals effectively override the more general identifier pattern. Literals are created in one of two ways. First, any double-quoted string used in a parser is automatically entered into the literals table of the associated lexer. Second, literals may be specified in the lexer grammar by means of the [literal option](#). In addition, the [testLiterals option](#) gives you fine-grained control over the generation of literal-testing code.

Common prefixes

Fixed-length common prefixes in lexer rules are best handled by increasing the [lookahead depth](#) of the lexer. For example, some operators from Java:

```

class MyLexer extends Lexer;
options {
    k=4;
}
GT : ">";
GE : ">=";
RSHIFT : ">>";
RSHIFT_ASSIGN : ">>=";
UNSIGNED_RSHIFT : ">>>";
UNSIGNED_RSHIFT_ASSIGN : ">>>=";

```

Token definition files

Token definitions can be transferred from one grammar to another by way of token definition files. This is accomplished using the [importVocab](#) and [exportVocab](#) options.

Character classes

Use the `~` operator to invert a character or set of characters. For example, to match any character other than newline, the following rule references `~'\n'`.

```
SL_COMMENT : "//" (~'\n')* '\n';
```

The `~` operator also inverts a character set:

```
NOT_WS : ~( ' ' | '\t' | '\n' | '\r' );
```

The range operator can be used to create sequential character sets:

```
DIGIT : '0'..'9' ;
```

Token Attributes

See the next section.

Lexical lookahead and the end-of-token symbol

A unique situation occurs when analyzing lexical grammars, one which is similar to the end-of-file condition when analyzing regular grammars. Consider how you would compute lookahead sets for the ('b' |) subrule in following rule B:

```
class L extends Lexer;

A      :      B 'b'
      ;

protected // only called from another lex rule
B      :      'x' ( 'b' | )
      ;
```

The lookahead for the first alternative of the subrule is clearly 'b'. The second alternative is empty and the lookahead set is the set of all characters that can follow references to the subrule, which is the follow set for rule B. In this case, the 'b' character follows the reference to B and is therefore the lookahead set for the empty alt indirectly. Because 'b' begins both alternatives, the parsing decision for the subrule is nondeterminism or ambiguous as we sometimes say. ANTLR will justly generate a warning for this subrule (unless you use the `warnWhenFollowAmbig` option).

Now, consider what would make sense for the lookahead if rule A did not exist and rule B was not protected (it was a complete token rather than a "subtoken"):

```
B      :      'x' ( 'b' | )
      ;
```

In this case, the empty alternative finds only the end of the rule as the lookahead with no other rules referencing it. In the worst case, **any** character could follow this rule (i.e., start the next token or error sequence). So, should not the lookahead for the empty alternative be the entire character vocabulary? And should not this result in a nondeterminism warning as it must conflict with the 'b' alternative? Conceptually, yes to both questions. From a practical standpoint, however, you are clearly saying "heh, match a 'b' on the end of token B if you find one." I argue that no warning should be generated and ANTLR's policy of matching elements as soon as possible makes sense here as well.

Another reason not to represent the lookahead as the entire vocabulary is that a vocabulary of `\u0000..\uFFFF` is really big (one set is $2^{16} / 32$ long words of memory!). Any alternative with '<end-of-token>' in its lookahead set will be pushed to the ELSE or DEFAULT clause by the code generator so that huge bitsets can be avoided.

The summary is that lookahead purely derived from hitting the end of a lexical rule (unreferenced by other rules) cannot be the cause of a nondeterminism. The following table summarizes a bunch of cases that will help you figure out when ANTLR will complain and when it will not.

<pre>X : 'q' ('a')? ('a')? ;</pre>	<p>The first subrule is nondeterministic as 'a' from second subrule (and end-of-token) are in the lookahead for exit branch of (...)?</p>
<pre>X : 'q' ('a')? ('c')? ;</pre>	<p>No nondeterminism.</p>
<pre>Y : 'y' X 'b' ; protected X : 'b' ;</pre>	<p>Nondeterminism in rule X.</p>
<pre>X : 'x' ('a' 'c' 'd')+ 'z' ('a')+ ;</pre>	<p>No nondeterminism as exit branch of loops see lookahead computed purely from end-of-token.</p>
<pre>Y : 'y' ('a')+ ('a')? ;</pre>	<p>Nondeterminism between 'a' of (...) + and exit branch as the exit can see the 'a' of the optional subrule. This would be a problem even if ('a')? were simply 'a'. A (...) * loop would report the same problem.</p>
<pre>X : 'y' ('a' 'b')+ 'a' 'c' ;</pre>	<p>At k=1, this is a nondeterminism for the (...)? since 'a' predicts staying in and exiting the loop. At k=2, no nondeterminism.</p>

<pre>Q : 'q' ('a')? ;</pre>	<p>Here, there is an empty alternative inside an optional subrule. A nondeterminism is reported as two paths predict end-of-token.</p>
---	--

You might be wondering why the first subrule below is ambiguous:

```
('a')? ('a')?
```

The answer is that the NFA to DFA conversion would result in a DFA with the 'a' transitions merged into a single state transition! This is ok for a DFA where you cannot have actions anywhere except after a complete match. Remember that ANTLR lets you do the following:

```
('a' {do-this})? ('a' {do-that})?
```

One other thing is important to know. Recall that alternatives in lexical rules are reordered according to their lookahead requirements, from highest to lowest.

```
A      :      'a'
      |      'a' 'b'
      ;
```

At $k=2$, ANTLR can see 'a' followed by '<end-of-token>' for the first alternative and 'a' followed by 'b' in the second. The lookahead at depth 2 for the first alternative being '<end-of-token>' suppressing a warning that depth two can match any character for the first alternative. To behave naturally and to generate good code when no warning is generated, ANTLR reorders the alternatives so that the code generated is similar to:

```
A() {
    if ( LA(1)=='a' && LA(2)=='b' ) { // alt 2
        match('a'); match('b');
    }
    else if ( LA(1)=='a' ) { // alt 1
        match('a')
    }
    else {error;}
}
```

Note the lack of lookahead test for depth 2 for alternative 1. When an empty alternative is present, ANTLR moves it to the end. For example,

```
A      :      'a'
      |
      |      'a' 'b'
      ;
```

results in code like this:

```
A() {
    if ( LA(1)=='a' && LA(2)=='b' ) { // alt 2
        match('a'); match('b');
    }
    else if ( LA(1)=='a' ) { // alt 1
```

```

                match('a')
            }
        else {
        }
    }

```

Note that there is no way for a lexing error to occur here (which makes sense because the rule is optional--though this rule only makes sense when `protected`).

Semantic predicates get moved along with their associated alternatives when the alternatives are sorted by lookahead depth. It would be weird if the addition of a `{true}?` predicate (which implicitly exists for each alternative) changed what the lexer recognized! The following rule is reordered so that alternative 2 is tested for first.

```

B      :      {true}? 'a'
        |      'a' 'b'
        ;

```

Syntactic predicates are **not** reordered. Mentioning the predicate after the rule it conflicts with results in an ambiguity such as is in this rule:

```

F      :      'c'
        |      ('c')=> 'c'
        ;

```

Other alternatives are, however, reordered with respect to the syntactic predicates even when a switch is generated for the LL(1) components and the syntactic predicates are pushed the default case. The following rule illustrates the point.

```

F      :      'b'
        |      { /* empty-path */ }
        |      ('c')=> 'c'
        |      'c'
        |      'd'
        |      'e'
        ;

```

Rule F's decision is generated as follows:

```

switch ( la_1) {
case 'b':
{
    match('b');
    break;
}
case 'd':
{
    match('d');
    break;
}
case 'e':
{
    match('e');
    break;
}
default:
    boolean synPredMatched15 = false;
    if (((la_1=='c')) {
        int _m15 = mark();
        synPredMatched15 = true;

```

```

        guessing++;
        try {
            match('c');
        }
        catch (RecognitionException pe) {
            synPredMatched15 = false;
        }
        rewind(_m15);
        guessing--;
    }
    if ( synPredMatched15 ) {
        match('c');
    }
    else if ((la_1=='c')) {
        match('c');
    }
    else {
        if ( guessing==0 ) {
            /* empty-path */
        }
    }
}

```

Notice how the empty path got moved after the test for the 'c' alternative.

Scanning Binary Files

Character literals are not limited to printable ASCII characters. To demonstrate the concept, imagine that you want to parse a binary file that contains strings and short integers. To distinguish between them, marker bytes are used according to the following format:

format	description
<code>\0' highbyte lowbyte</code>	Short integer
<code>\1' string of non-\2' chars \2'</code>	String

Sample input (274 followed by "a test") might look like the following in hex (output from UNIX `od -h` command):

```
0000000000    00 01 12 01 61 20 74 65 73 74 02
```

or as viewed as characters:

```
0000000000    \0 001 022 001 a      t e s t 002
```

The parser is trivially just a (...) around the two types of input tokens:

```

class DataParser extends Parser;

file:  (    sh:SHORT
          {System.out.println(sh.getText());}
        |    st:STRING
          {System.out.println("\ " +
                               st.getText()+"\ ");}
        )+
      ;

```

All of the interesting stuff happens in the lexer. First, define the class and set the vocabulary to be all 8

bit binary values:

```
class DataLexer extends Lexer;
options {
    charVocabulary = '\u0000'..' \u00FF';
}
```

Then, define the two tokens according to the specifications, with markers around the string and a single marker byte in front of the short:

```
SHORT
: // match the marker followed by any 2 bytes
  '\0' high:.. lo:..
  {
    // pack the bytes into a two-byte short
    int v = (((int)high)<<8) + lo;
    // make a string out of the value
    $setText(""+v);
  }
;

STRING
: '\1'! // begin string (discard)
  ( ~'\2' )*
  '\2'! // end string (discard)
;
```

To invoke the parser, use something like the following:

```
import java.io.*;

class Main {
    public static void main(String[] args) {
        try {
            // use DataInputStream to grab bytes
            DataLexer lexer =
                new DataLexer(
                    new DataInputStream(System.in)
                );
            DataParser parser =
                new DataParser(lexer);
            parser.file();
        } catch (Exception e) {
            System.err.println("exception: "+e);
        }
    }
}
```

Scanning Unicode Characters

ANTLR (as of 2.7.1) allows you to recognize input composed of Unicode characters; that is, you are not restricted to 8 bit ASCII characters. I would like to emphasize that ANTLR *allows*, but does yet not *support* Unicode as there is more work to be done. For example, end-of-file is currently incorrectly specified:

```
CharScanner.EOF_CHAR=(char)-1;
```

This must be an integer -1 not char, which is actually narrowed to 0xFFFF via the cast. I have to go through the entire code base looking for these problems. Plus, we should really have a special syntax to mean "java identifier character" and some standard encodings for non-Western character sets etc... I

expect 2.7.3 to add nice predefined character blocks like `LETTER`.

The following is a very simple example of how to match a series of space-separated identifiers.

```
class L extends Lexer;

options {
    // Allow any char but \uFFFF (16 bit -1)
    charVocabulary='\u0000'..' \uFFFE';
}

{
    private static boolean done = false;

    public void uponEOF()
        throws TokenStreamException, CharStreamException
    {
        done=true;
    }

    public static void main(String[] args) throws Exception {
        L lexer = new L(System.in);
        while ( !done ) {
            Token t = lexer.nextToken();
            System.out.println("Token: "+t);
        }
    }
}

ID      :      ID_START_LETTER ( ID_LETTER )*
;

WS      :      ( ' ' | '\n' ) {$setType(Token.SKIP);}
;

protected
ID_START_LETTER
:      '$'
|      '-'
|      'a'..'z'
|      '\u0080'..' \ufffe'
;

protected
ID_LETTER
:      ID_START_LETTER
|      '0'..'9'
;
```

A final note on Unicode. The `~x` "not" operator includes everything in your specified vocabulary (up to 16 bit character space) except `x`. For example,

```
~( '$' | 'a'..'z' )
```

results in every unicode character except '\$' and lowercase latin-1 letters, assuming your `charVocabulary` is `0..FFFF`.

Manipulating Token Text and Objects

Once you have specified what to match in a lexical rule, you may ask "what can I discover about what

will be matched for each rule element?" ANTLR allows you to label the various elements and, at parse-time, access the text matched for the element. You can even specify the token object to return from the rule and, hence, from the lexer to the parser. This section describes the text and token object handling characteristics of ANTLR.

Manipulating the Text of a Lexical Rule

There are times when you want to look at the text matched for the current rule, alter it, or set the text of a rule to a new string. The most common case is when you want to simply discard the text associated with a few of the elements that are matched for a rule such as quotes.

ANTLR provides the '!' operator that lets you indicate certain elements should not contribute to the text for a token being recognized. The '!' operator is used just like when building trees in the parser. For example, if you are matching the HTML tags and you do not want the '<' and '>' characters returned as part of the token text, you could manually remove them from the token's text before they are returned, but a better way is to suffix the unwanted characters with '!'. For example, the
 tag might be recognized as follows:

```
BR : '<!' "br" '>!' ; // discard < and >
```

Suffixing a lexical rule reference with '!' forces the text matched by the invoked rule to be discarded (it will not appear in the text for the invoking rule). For example, if you do not care about the mantissa of a floating point number, you can suffix the rule that matches it with a '!':

```
FLOAT : INT ('.'! INT!)? ; // keep only first INT
```

As a shorthand notation, you may suffix an alternative or rule with '!' to indicate the alternative or rule should not pass any text back to the invoking rule or parser (if nonprotected):

```
// ! on rule: nothing is auto added to text of rule.
rule! : ... ;

// ! on alt: nothing is auto added to text for alt
rule : ... |! ...;
```

Item suffixed with '!'	Effect
char or string literal	Do not add text for this atom to current rule's text.
rule reference	Do not add text for matched while recognizing this rule to current rule's text.
alternative	Nothing that is matched by alternative is added to current rule's text; the enclosing rule contributes nothing to any invoking rule's text. For nonprotected rules, the text for the token returned to parser is blank.
rule definition	Nothing that is matched by any alternative is added to current rule's text; the rule contributes nothing to any invoking rule's text. For nonprotected rules, the text for the token returned to parser is blank.

While the '!' implies that the text is not added to the text for the current rule, you can label an element to access the text (via the token if the element is a rule reference).

In terms of implementation, the characters are always added to the current text buffer, but are carved out when necessary (as this will be the exception rather than the rule, making the normal case efficient).

The '!' operator is great for discarding certain characters or groups of characters, but what about the case where you want to insert characters or totally reset the text for a rule or token? ANTLR provides a series of special methods to do this (we prefix the methods with '\$' because Java does not have a macro facility and ANTLR must recognize the special methods in your actions). The following table

summarizes.

Method	Description/Translation
<code>\$append(x)</code>	Append <code>x</code> to the text of the surrounding rule. Translation: <code>text.append(x)</code>
<code>\$setText(x)</code>	Set the text of the surrounding rule to <code>x</code> . Translation: <code>text.setLength(_begin); text.append(x)</code>
<code>\$getText</code>	Return a <code>String</code> of the text for the surrounding rule. Translation: <code>new String(text.getBuffer(), _begin, text.length() - _begin)</code>
<code>\$setToken(x)</code>	Set the token object that this rule is to return. See the section on Token Object Creation . Translation: <code>_token = x</code>
<code>\$setType(x)</code>	Set the token type of the surrounding rule. Translation: <code>_ttype = x</code>
<code>setText(x)</code>	Set the text for the entire token being recognized regardless of what rule the action is in. No translation.
<code>getText()</code>	Get the text for the entire token being recognized regardless of what rule the action is in. No translation.

One of the great things about an ANTLR generated lexer is that the text of a token can be modified incrementally as the token is recognized (an impossible task for a DFA-based lexer):

```
STRING: '"' ( ESCAPE | ~('"' | '\\') )* '"' ;
```

```
protected
ESCAPE
    :    '\\\
        ( 'n' { $setText("\n"); }
        | 'r' { $setText("\r"); }
        | 't' { $setText("\t"); }
        | '"' { $setText("\""); }
        )
    ;
```

Token Object Creation

Because lexical rules can call other rules just like in the parser, you sometimes want to know what text was matched for that portion of the token being matched. To support this, ANTLR allows you to label lexical rules and obtain a `Token` object representing the text, token type, line number, etc... matched for that rule reference. This ability corresponds to be able to access the text matched for a lexical state in a DFA-based lexer. For example, here is a simple rule that prints out the text matched for a rule reference, `INT`.

```
INDEX    :    '[' i:INT '['
           {System.out.println(i.getText());}
           ;

INT      :    ('0'..'9')+ ;
```

If you moved the labeled reference and action to a parser, it would do the same thing (match an integer and print it out).

All lexical rules *conceptually* return a `Token` object, but in practice this would be inefficient. ANTLR generates methods so that a token object is created only if any invoking reference is labeled (indicating they want the token object). Imagine another rule that calls `INT` without a label.

```
FLOAT      :      INT ( '.' INT)? ;
```

In this case, no token object is created for either reference to `INT`. You will notice a boolean argument to every lexical rule that tells it whether or not a token object should be created and returned (via a member variable). All nonprotected rules (those that are "exposed" to the parser) must always generate tokens, which are passed back to the parser.

Heterogeneous Token Object Streams

While token creation is normally handled automatically, you can also manually specify the token object to be returned from a lexical rule. The advantage is that you can pass heterogeneous token objects back to the parser, which is extremely useful for parsing languages with complicated tokens such as HTML (the `` and `<table>` tokens, for example, can have lots of attributes). Here is a rule for the `` tag that returns a token object of type `ImageToken`:

```
IMAGE
{
  Attributes attrs;
}
: "<img " attrs=ATTRIBUTES '>'
  {
    ImageToken t = new ImageToken(IMAGE,$getText);
    t.setAttributes(attrs);
    $setToken(t);
  }
;
ATTRIBUTES returns [Attributes a]
: ...
;
```

The `$setToken` function specifies that its argument is to be returned when the rule exits. The parser will receive this specific object instead of a `CommonToken` or whatever else you may have specified with the `Lexer.setTokenObjectClass` method. The action in rule `IMAGE` references a token type, `IMAGE`, and a lexical rule references, `ATTRIBUTES`, which matches all of the attributes of an image tag and returns them in a data structure called `Attributes`.

What would it mean for rule `IMAGE` to be protected (i.e., referenced only from other lexical rules rather than from `nextToken`)? Any invoking labeled rule reference would receive the object (not the parser) and could examine it, or manipulate it, or pass it on to the invoker of that rule. For example, if `IMAGE` were called from `TAGS` rather than being nonprotected, rule `TAGS` would have to pass the token object back to the parser for it.

```
TAGS : IMG:IMAGE
      {$setToken(img);} // pass to parser
      | PARAGRAPH // probably has no special token
      | ...
      ;
```

Setting the token object for a nonprotected rule invoked without a label has no effect other than to waste time creating an object that will not be used.

We use a `CharScanner` member `_returnToken` to do the return in order to not conflict with return values used by the grammar developer. For example,

```
PTAG: "<p>" {$setToken(new ParagraphToken($$));} ;
```

which would be translated to something like:

```
protected final void mPTAG()
    throws RecognitionException, CharStreamException,
           TokenStreamException {
    Token _token = null;
    match("<p>");
    _returnToken =
        new ParagraphToken(text-of-current-rule);
}
```

Filtering Input Streams

You often want to perform an action upon seeing a pattern or two in a complicated input stream, such as pulling out links in an HTML file. One solution is to take the HTML grammar and just put actions where you want. Using a complete grammar is overkill and you may not have a complete grammar to start with.

ANTLR provides a mechanism similar to AWK that lets you say "here are the patterns I'm interested in--ignore everything else." Naturally, AWK is limited to regular expressions whereas ANTLR accepts context-free grammars (Uber-AWK?). For example, consider pulling out the <p> and
 tags from an arbitrary HTML file. Using the filter option, this is easy:

```
class T extends Lexer;
options {
    k=2;
    filter=true;
}

P : "<p>" ;
BR: "<br>" ;
```

In this "mode", there is no possibility of a syntax error. Either the pattern is matched exactly or it is filtered out.

This works very well for many cases, but is not sophisticated enough to handle the situation where you want "almost matches" to be reported as errors. Consider the addition of the <table...> tag to the previous grammar:

```
class T extends Lexer;
options {
    k=2;
    filter = true;
}

P : "<p>" ;
BR: "<br>" ;
TABLE : "<table" (WS)? (ATTRIBUTE)* (WS)? '>' ;
WS : ' ' | '\t' | '\n' ;
ATTRIBUTE : ... ;
```

Now, consider input "<table 8 = width ;>" (a bogus table definition). As is, the lexer would simply scarf past this input without "noticing" the invalid table. What if you want to indicate that a bad table definition was found as opposed to ignoring it? Call method

```
setCommitToPath(boolean commit)
```

in your TABLE rule to indicate that you want the lexer to commit to recognizing the table tag:

```
TABLE
    :   "<table" (WS)?
        {setCommitToPath(true);}
        (ATTRIBUTE)* (WS)? '>'
    ;
```

Input "<table 8 = width ;>" would result in a syntax error. Note the placement after the whitespace recognition; you do not want <tabletop> reported as a bad table (you want to ignore it).

One further complication in filtering: What if the "skip language" (the stuff in between valid tokens or tokens of interest) cannot be correctly handled by simply consuming a character and trying again for a valid token? You may want to ignore comments or strings or whatever. In that case, you can specify a rule that scarfs anything between tokens of interest by using option `filter=RULE`. For example, the grammar below filters for <p> and
 tags as before, but also prints out any other tag (<...>) encountered.

```
class T extends Lexer;
options {
    k=2;
    filter=IGNORE;
    charVocabulary = '\3'..'177';
}

P : "<p>" ;
BR : "<br>" ;

protected
IGNORE
    :   '<' (~'>)* '>'
        {System.out.println("bad tag: "+getText);}
        |   ("r\n" | '\r' | '\n' ) {newline();}
        |   .
    ;
```

Notice that the filter rule must track newlines in the general case where the lexer might emit error messages so that the line number is not stuck at 0.

The filter rule is invoked either when the lookahead (in `nextToken`) predicts none of the nonprotected lexical rules or when one of those rules fails. In the latter case, the input is rolled back before attempting the filter rule. Option `filter=true` is like having a filter rule such as:

```
IGNORE : . ;
```

Actions in regular lexical rules are executed even if the rule fails and the filter rule is called. To do otherwise would require every valid token to be matched twice (once to match and once to do the actions like a syntactic predicate)! Plus, there are few actions in lexer rules (usually they are at the end at which point an error cannot occur).

Is the filter rule called when `commit-to-path` is true and an error is found in a lexer rule? No, an error is reported as with `filter=true`.

What happens if there is a syntax error in the filter rule? Well, you can either put an exception handler on the filter rule or accept the default behavior, which is to consume a character and begin looking for another valid token.

In summary, the filter option allows you to:

1. Filter like awk (only perfect matches reported--no such thing as syntax error)
2. Filter like awk + catch poorly-formed matches (that is, "almost matches" like <table 8=3;> result in an error)
3. Filter but specify the skip language

ANTLR Masquerading as SED

To make ANTLR generate lexers that behave like the UNIX utility sed (copy standard in to standard out except as specified by the replace patterns), use a filter rule that does the input to output copying:

```
class T extends Lexer; options { k=2; filter=IGNORE; charVocabulary =
'\3'..'177'; }
```

```
P : "<p>" {System.out.print("<P>");};
BR : "<br>" {System.out.print("<BR>");};
```

```
protected
IGNORE
: ( "\r\n" | '\r' | '\n' )
  {newline(); System.out.println(" ");}
| c: . {System.out.print(c);}
;
```

This example dumps anything other than <p> and
 tags to standard out and pushes lowercase <p> and
 to uppercase. Works great.

Nongreedy Subrules

Quick: What does the following match?

```
BLOCK : '{' (.)* '}' ;
```

Your first reaction is that it matches any set of characters inside of curly quotes. In reality, it matches '{' followed by every single character left on the input stream! Why? Well, because ANTLR loops are *greedy*--they consume as much input as they can match. Since the wildcard matches any character, it consumes the '}' and beyond. This is a pain for matching strings, comments and so on.

Why can't we switch it around so that it consumes only until it sees something on the input stream that matches what **follows** the loop, such as the '}'? That is, why can't we make loops *nongreedy*? The answer is we can, but sometimes you want greedy and sometimes you want nongreedy (PERL has both kinds of closure loops now too). Unfortunately, parsers usually want greedy and lexers usually want nongreedy loops. Rather than make the same syntax behave differently in the various situations, Terence decided to leave the semantics of loops as they are (greedy) and make a subrule option to make loops nongreedy.

Greedy Subrules

I have yet to see a case when building a parser grammar where I did not want a subrule to match as much input as possible. For example, the solution to the classic if-then-else clause ambiguity is to match the

"else" as soon as possible:

```
stat : "if" expr "then" stat ("else" stat)?
      | ...
      ;
```

This ambiguity (which statement should the "else" be attached to) results in a parser nondeterminism. ANTLR warns you about the (. . .)? subrule as follows:

```
warning: line 3: nondeterminism upon
         k==1:"else"
         between alts 1 and 2 of block
```

If, on the other hand, you make it clear to ANTLR that you want the subrule to match greedily (i.e., assume the default behavior), ANTLR will not generate the warning. Use the `greedy` subrule option to tell ANTLR what you want:

```
stat : "if" expr "then" stat
      ( options {greedy=true;} : "else" stat)?
      | ID
      ;
```

You are not altering the behavior really, since ANTLR was going to choose to match the "else" anyway, but you have avoided a warning message.

There is no such thing as a nongreedy (. . .)? subrule because telling an optional subrule not to match anything is the same as not specifying the subrule in the first place. If you make the subrule nongreedy, you will see:

```
warning in greedy.g: line(4),
         Being nongreedy only makes sense
         for (...) + and (...) *
warning: line 4: nondeterminism upon
         k==1:"else"
         between alts 1 and 2 of block
```

Greedy subrules are very useful in the lexer also. If you want to grab any whitespace on the end of a token definition, you can try `(WS)?` for some whitespace rule `WS`:

```
ID : ('a'..'z')+ (WS)? ;
```

However, if you want to match `ID` in a loop in another rule that could also match whitespace, you will run into a nondeterminism warning. Here is a contrived loop that conflicts with the `(WS)?` in `ID`:

```
LOOP : ( ID
        | WS
        )+
        ;
```

The whitespace on the end of the `ID` could be matched in `ID` or in `LOOP` now. ANTLR chooses to match the `WS` immediately, in `ID`. To shut off the warning, simply tell ANTLR that you mean for it to be greedy, it's default behavior:

```
ID : ('a'..'z')+ (options {greedy=true;}:WS)? ;
```

Nongreedy Lexer Subrules

ANTLR's default behavior of matching as much as possible in loops and optional subrules is sometimes not what you want in lexer grammars. Most loops that match "a bunch of characters" in between markers, like curly braces or quotes, should be nongreedy loops. For example, to match a nonnested block of characters between curly braces, you want to say:

```
CURLY_BLOCK_SCARF
:   '{' (.)* '}'
;
```

Unfortunately, this does not work--it will consume everything after the '{' until the end of the input. The wildcard matches anything including '}' and so the loop merrily consumes past the ending curly brace.

To force ANTLR to break out of the loop when it sees a lookahead sequence consistent with what follows the loop, use the greedy subrule option:

```
CURLY_BLOCK_SCARF
:   '{'
    (
        options {
            greedy=false;
        }
        :
        .*
    )
    '}'
;
```

To properly take care of newlines inside the block, you should really use the following version that "traps" newlines and bumps up the line counter:

```
CURLY_BLOCK_SCARF
:   '{'
    (
        options {
            greedy=false;
        }
        :
        | '\r' ('\n')? {newline();}
        | '\n'         {newline();}
        |
        .
    )
    '}'
;
```

Limitations of Nongreedy Subrules

What happens when what follows a nongreedy subrule is not as simple as a single "marker" character like a right curly brace (i.e., what about when you need $k > 1$ to break out of a loop)? ANTLR will either "do the right thing" or warn you that it might not.

First, consider the matching C comments:

```
CMT : "/*" (.)* "*/" ;
```

As with the curly brace matching, this rule will not stop at the end marker because the wildcard matches

the "*" end marker as well. You must tell ANTLR to make the loop nongreedy:

```
CMT : "/*" (options {greedy=false;} :.)* "*/" ;
```

You will not get an error and ANTLR will generate an exit branch

```
do {
    // nongreedy exit test
    if ((LA(1)=='*')) break _loop3;
    ...
}
```

Ooops. $k=1$, which is not enough lookahead. ANTLR did not generate a warning because it assumes you are providing enough lookahead for all nongreedy subrules. ANTLR cannot determine how much lookahead to use or how much is enough because, by definition, the decision is ambiguous--it simply generates a decision using the maximum lookahead.

You must provide enough lookahead to let ANTLR see the full end marker:

```
class L extends Lexer;
options {
    k=2;
}

CMT : "/*" (options {greedy=false;} :.)* "*/" ;
```

Now, ANTLR will generate an exit branch using $k=2$.

```
do {
    // nongreedy exit test
    if ((LA(1)=='*' && (LA(2)=='/'))
        break _loop3;
    ...
}
```

If you increase k to 3, ANTLR will generate an exit branch using $k=3$ instead of 2, even though 2 is sufficient. We know that $k=2$ is ok, but ANTLR is faced with a nondeterminism as it will use as much information as it has to yield a deterministic parser.

There is one more issue that you should be aware of. Because ANTLR generates linear approximate decisions instead of full $LL(k)$ decisions, complicated "end markers" can confuse ANTLR. Fortunately, ANTLR knows when it is confused and will let you know.

Consider a simple contrived example where a loop matches either `ab` or `cd`:

```
R : ( options {greedy=false;}
    : ("ab" | "cd")
    )+
    ("ad" | "cb")
    ;
```

Following the loop, the grammar can match `ad` or `cb`. These exact sequences are not a problem for a full $LL(k)$ decision, but due to the extreme compression of the linear approximate decision, ANTLR will generate an inaccurate exit branch. In other words, the loop will exit, for example, on `ab` even though that sequence cannot be matched following the loop. The exit condition is as follows:

```
// nongreedy exit test
```

```
if ( _cnt10>=1 && (LA(1)=='a' || LA(1)=='c') &&
    (LA(2)=='b' || LA(2)=='d')) break _loop10;
```

where the `_cnt10` term ensures the loop goes around at least once (but has nothing to do with the nongreedy exit branch condition really). Note that ANTLR has compressed all characters that can possibly be matched at a lookahead depth into a single set, thus, destroying the sequence information. The decision matches the cross product of the sets, including the spurious lookahead sequences such as `ab`.

Fortunately, ANTLR knows when a decision falls between its approximate decision and a full LL(k) decision--it warns you as follows:

```
warning in greedy.g: line(3),
    nongreedy block may exit incorrectly due
    to limitations of linear approximate lookahead
    (first k-1 sets in lookahead not singleton).
```

The parenthetical remark gives you a hint that some $k > 1$ lookahead sequences are correctly predictable even with the linear approximate lookahead compression. The idea is that if all sets for depths $1..(k-1)$ are singleton sets (exactly one lookahead sequence for first $k-1$ characters) then linear approximate lookahead compression does not weaken your parser. So, the following variant does not yield a warning since the exit branch is linear approximate as well as full LL(k):

```
R : ( options {greedy=false;}
    :
    )+
    ("ad" | "ae")
    ;
```

The exit branch decision now tests lookahead as follows:

```
(LA(1)=='a') && (LA(2)=='d' || LA(2)=='e')
```

which accurately predicts when to exit.

Lexical States

With DFA-based lexer generators such as `lex`, you often need to match pieces of your input with separate sets of rules called lexical states. In ANTLR, you can simply define another rule and call it like any other to switch "states". Better yet, this "state" rule can be reused by other parts of your lexer grammar because the method return stack tells the lexer which rule to return to. DFAs have no stacks unlike recursive-descent parsers and, hence, can only switch back to one hard-coded rule.

Consider an example where you would normally see a lexical state--that of matching escape characters within a string. You would attach an action to the double quote character that switched state to a `STRING_STATE` state. This subordinate state would then define rules for matching the various escapes and finally define a rule for double quote that whose action would switch you back to the normal lexical state. To demonstrate the solution with ANTLR, let's start with just a simple string definition:

```
/** match anything between double-quotes */
STRING : '"' (~'"')* '"' ;
```

To allow escape characters like `\t`, you need to add an alternative to the `(...)*` loop. (You could do that with a DFA-based lexer as well, but you could not have any actions associated with the escape character alternatives to do a replacement etc...). For convenience,

collect all escape sequences in another rule called ESC:

```
STRING : '"' (ESC | ~('\|\'|'"'))* '"' ;
```

```
protected
```

```
ESC : '\\\' ('t' {...} | '"' {...} )* ;
```

The `protected` is a (poorly named) indicator that the rule, `ESC`, is not a token to be returned to the parser. It just means that the `nextToken` method does not attempt to route recognition flow directly to that rule--`ESC` must be called from another lexer rule.

This works for simple escapes, but does not include escapes like `\20`. To fix it, just add a reference to another rule `INT` that you probably have already defined.

```
STRING : '"' (ESC | ~('\|\'|'"'))* '"' ;
```

```
protected
```

```
ESC : '\\\' ('t' {...} | '"' {...} | INT {...})* ;
```

```
INT : ('0'..'9')+ ;
```

Notice that `INT` is a real token that you want the parser to see so the rule is not `protected`. A rule may invoke any other rule, `protected` or not.

Lexical states with DFA-based lexers merely allow you to recognize complicated tokens more easily--the parser has no idea the contortions the lexer goes through. There are some situations where you might want multiple, completely-separate lexers to feed your parser. One such situation is where you have an embedded language such as javadoc comments. ANTLR has the ability to switch between multiple lexers using a token stream multiplexor. Please see the discussion in [streams](#).

The End Of File Condition

A method is available for reacting to the end of file condition as if it were an event; e.g., you might want to pop the lexer state at the end of an include file. This method, `CharScanner.uponEOF()`, is called from `nextToken()` right before the scanner returns an `EOF_TYPE` token object to parser:

```
public void uponEOF() |
    throws TokenStreamException, CharStreamException;
```

This event is not generated during a syntactic predicate evaluation (i.e., when the parser is guessing) nor in the middle of the recognition of a lexical rule (that would be an IO exception). This event is generated only after the complete evaluation of the last token and upon the next request from the parser for a token.

You can throw exceptions from this method like "Heh, premature eof" or a retry stream exception. See the `includeFile/P.g` for an example usage.

Case sensitivity

You may use option `caseSensitive=false` in the lexer to indicate that you do not want case to be significant when matching characters against the input stream. For example, you want element `'d'` to match either upper or lowercase `D`, however, you do not want to change the case of the input stream. We have implemented this feature by having the lexer's `LA()` lookahead method return lowercase versions of

the characters. Method `consume()` still adds the original characters to the string buffer associated with a token. We make the following notes:

- The lowercasing is done by a method `toLowerCase()` in the lexer. This can be overridden to get more specific case processing. using option `caseSensitive` calls method `CharScanner.setCaseSensitive(...)`, which you can also call before (or during I suppose) the parse.
- ANTLR issues a warning when `caseSensitive=false` and uppercase ASCII characters are used in character or string literals.

Case sensitivity for literals is handled separately. That is, set lexer option `caseSensitiveLiterals` to `false` when you want the literals testing to be case-insensitive. Implementing this required changes to the literals table. Instead of adding a `String`, it adds an `ANTLRHashString` that implements a case-insensitive or case-sensitive hashing as desired.

Note: ANTLR checks the characters of a lexer string to make sure they are lowercase, but does not process escapes correctly--put that one on the "to do" list.

Ignoring whitespace in the lexer

One of the great things about ANTLR is that it generates full predicated-LL(k) lexers rather than the weaker (albeit sometimes easier-to-specify) DFA-based lexers of DLG. With such power, you are tempted (and encouraged) to do real parsing in the lexer. A great example of this is HTML parsing, which begs for a two-level parse: the lexer parses all the attributes and so on within a tag, but the parser does overall document structure and ordering of the tags etc... The problem with parsing within a lexer is that you encounter the usual "ignore whitespace" issue as you do with regular parsing.

For example, consider matching the `<table>` tag of HTML, which has many attributes that can be specified within the tag. A first attempt might yield:

```
OTABLE    :    "<table" (ATTR)* '>'
          ;
```

Unfortunately, input `"<table border=1>"` does not parse because of the blank character after the `table` identifier. The solution is not to simply have the lexer ignore whitespace as it is read in because the lookahead computations must see the whitespace characters that will be found in the input stream. Further, defining whitespace as a rudimentary set of things to ignore does not handle all cases, particularly difficult ones, such as comments inside tags like

```
<table <!--wow...a comment--> border=1>
```

The correct solution is to specify a rule that is called after each lexical element (character, string literal, or lexical rule reference). We provide the lexer rule option `ignore` to let you specify the rule to use as whitespace. The solution to our HTML whitespace problem is therefore:

```
TABLE
options { ignore=WS; }
      :    "<table" (ATTR)* '>'
      ;

// can be protected or non-protected rule
WS    :    ' ' | '\n' | COMMENT | ...
      ;
```

We think this is cool and we hope it encourages you to do more and more interesting things in the lexer!

Oh, almost forgot. There is a **bug** in that an extra whitespace reference is inserted after the end of a lexer alternative if the last element is an action. The effect is to include any whitespace following that token in that token's text.

Tracking Line Information

Each lexer object has a `line` member that can be incremented by calling `newline()` or by simply changing its value (e.g., when processing `#line` directives in C).

```
SL_COMMENT : "//" (~'\n')* '\n' {newline();} ;
```

Do not forget to split out `'\n'` recognition when using the not operator to read until a stopping character such as:

```
BLOCK : '('
        ( '\n' { newline(); }
          | ~( '\n' | ')' )
        )*
      ')'
      ;
```

Another way to track line information is to override the `consume()` method:

Tracking Column Information

ANTLR (2.7.1 and beyond), tracks character column information so that each token knows what column it starts in; columns start at 1 just like line numbers. The `CharScanner.consume()` method asks method `tab()` to update the column number if it sees a tab, else it just increments the column number:

```
...
if ( c=='\t' ) {
    tab();
}
else {
    inputState.column++;
}
}
```

By default, `tab()` is defined as follows:

```
/**
 * advance the current column number by an appropriate
 * amount. If you do not override this to specify how
 * much to jump for a tab, then tabs are counted as
 * one char. This method is called from consume().
 */
public void tab() {
    // update inputState.column as function of
    // inputState.column and tab stops.
    // For example, if tab stops are columns 1
    // and 5 etc... and column is 3, then add 2
    // to column.
    inputState.column++;
}
```

Upon new line, the lexer needs to reset the column number to 1. Here is the default implementation of `CharScanner.newline()`:

```
public void newline() {
    inputState.line++;
    inputState.column = 1;
}
```

Do not forget to call `newline()` in your lexer rule that matches `'\n'` lest the column number not be reset to 1 at the start of a line.

The shared input state object for a lexer is actually the critter that tracks the column number (as well as the starting column of the current token):

```
public class LexerSharedInputState {
    protected int column=1;
    protected int line=1;
    protected int tokenStartColumn = 1;
    protected int tokenStartLine = 1;
    ...
}
```

If you want to handle tabs in your lexer, just implement a method like the following to override the standard behavior.

```
/** set tabs to 4, just round column up to next tab + 1
12345678901234567890
  x  x  x  x
*/
public void tab() {
    int t = 4;
    int c = getColumn();
    int nc = (((c-1)/t)+1)*t+1;
    setColumn( nc );
}
```

See the `examples/java/columns` directory for the complete example.

Using Explicit Lookahead

On rare occasions, you may find it useful to explicitly test the lexer lookahead in say a semantic predicate to help direct the parse. For example, `/*...*/` comments have a two character stopping symbol. The following example demonstrates how to use the second symbol of lookahead to distinguish between a single `'/'` and a `"*/"`:

```
ML_COMMENT
:    "/"*
    ( { LA(2)!='/' }? '*'
    | '\n' { newline(); }
    | ~( '*' | '\n' )
    )*
    "*/"
;
```

The same effect might be possible via a syntactic predicate, but would be much slower than a semantic

predicate. A DFA-based lexer handles this with no problem because they use a bunch of (what amount to) gotos whereas we're stuck with structured elements like while-loops.

A Surprising Use of A Lexer: Parsing

The following set of rules match arithmetical expressions in a lexer **not** a parser (whitespace between elements is not allowed in this example but can easily be handled by specifying rule option `ignore` for each rule):

```

EXPR
{ int val; }
  :   val=ADDEXPR
    { System.out.println(val); }
  ;

protected
ADDEXPR returns [int val]
{ int tmp; }
  :   val=MULTEXPR
    ( '+' tmp=MULTEXPR { val += tmp; }
    | '-' tmp=MULTEXPR { val -= tmp; }
    )*
  ;

protected
MULTEXPR returns [int val]
{ int tmp; }
  :   val=ATOM
    ( '*' tmp=ATOM { val *= tmp; }
    | '/' tmp=ATOM { val /= tmp; }
    )*
  ;

protected
ATOM returns [int val]
  :   val=INT
    | '(' val=ADDEXPR ')'
  ;

protected
INT returns [int val]
  :   ('0'..'9')+
    {val=Integer.valueOf($getText);}
  ;

```

But...We've Always Used Automata For Lexical Analysis!

Lexical analyzers were all built by hand in the early days of compilers until DFAs took over as the scanner implementation of choice. DFAs have several advantages over hand-built scanners:

- DFAs can easily be built from terse regular expressions.
- DFAs do automatic left-factoring of common (possibly infinite) left-prefixes. In a hand-built scanner, you have to find and factor out all common prefixes. For example, consider writing a lexer to match integers and floats. The regular expressions are straightforward:

```
integer : "[0-9]+" ;
```

```
real      : "[0-9]+{.[0-9]}*|.[0-9]+" ;
```

Building a scanner for this would require factoring out the common `[0-9]+`. For example, a scanner might look like:

```
Token nextToken() {
    if ( Character.isDigit(c) ) {
        match an integer
        if ( c=='.' ) {
            match another integer
            return new Token(REAL);
        }
        else {
            return new Token(INT);
        }
    }
    else if ( c=='.' ) {
        match a float starting with .
        return new Token(REAL);
    }
    else ...
}
```

Conversely, hand-built scanners have the following advantages over DFA implementations:

- Hand-built scanners are not limited to the regular class of languages. They may use semantic information and method calls during recognition whereas a DFA has no stack and is typically not semantically predicated.
- Unicode (16 bit values) is handled for free whereas DFAs typically have fits about anything but 8 bit characters.
- DFAs are tables of integers and are, consequently, very hard to debug and examine.
- A tuned hand-built scanner can be faster than a DFA. For example, simulating the DFA to match `[0-9]+` requires n DFA state transitions where n is the length of the integer in characters.

Tom Pennello of Metaware back in 1986 ("Very Fast LR Parsing") generated LR-based parsers in machine code that used the program counter to do state transitions rather than simulating the PDA. He got a huge speed up in parse time. We can extrapolate from this experiment that avoiding a state machine simulator in favor of raw code results in a speed up.

So, what approach does ANTLR take? Neither! ANTLR allows you to specify lexical items with expressions, but generates a lexer for you that mimics what you would generate by hand. The only drawback is that you still have to do the left-factoring for some token definitions (but at least it is done with expressions and not code). This hybrid approach allows you to build lexers that are much stronger and faster than DFA-based lexers while avoiding much of the overhead of writing the lexer yourself.

In summary, specifying regular expressions is simpler and shorter than writing a hand-built lexer, but hand-built lexers are faster, stronger, able to handle unicode, and easy to debug. This analysis has led many programmers to write hand-built lexers even when DFA-generation tools such as `lex` and `d1g` are commonly-available. PCCTS 1.xx made a parallel argument concerning PDA-based LR parsers and recursive-descent LL-based parsers. As a final justification, we note that writing lexers is trivial compared to building parsers; also, once you build a lexer you will reuse it with small modifications in the future.

Version: \$Id: //depot/code/org.antlr/release/antlr-2.7.3/doc/lexer.html#1 \$

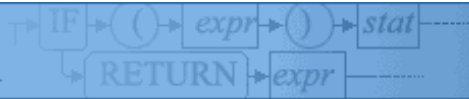

Latest version is 2.7.3.

Download now! »

DOWNLOAD[Home](#)

SEARCH

[Download](#)[News](#)[Using ANTLR](#)

ANTLR Tree Parsers

ANTLR Tree Parsers

[Documentation](#)[FAQ](#)[Articles](#)[Grammars](#)[File Sharing](#)[Code API](#)[Tech Support](#)*Or, The Entity Formerly Known As SORCERER*

ANTLR 2.xx helps you build intermediate form trees (ASTs) by augmenting a grammar with tree operators, rewrite rules, and actions. ANTLR also allows you to specify the grammatical structure of ASTs, thus, supporting the manipulation or simple walking of trees to produce translations.

Formerly, a separate tool, SORCERER, was used to generate tree parsers, but ANTLR has taken over this role. ANTLR now builds recognizers for streams of characters, tokens, or tree nodes.

[About ANTLR](#)

What's a tree parser?

[What is ANTLR](#)[Why use ANTLR](#)[Showcase](#)[Testimonials](#)[Getting Started](#)[Software License](#)[ANTLR WebLogs](#)

Parsing is the application of grammatical structure to a stream of input symbols. ANTLR takes this further than most tools and considers a tree to be a stream of nodes, albeit in two dimensions. In fact, the only real difference in ANTLR's code generation for token stream parsing versus tree parsing lies in the testing of lookahead, rule-method definition headers, and the introduction of a two-dimensional tree structure code-generation template.

What kinds of trees can be parsed?

ANTLR tree parsers can walk any tree that implements the AST interface, which imposes a child-sibling like structure to whatever tree data-structure you may have. The important navigation methods are:

- `getFirstChild`: Return a reference to the first child of the sibling list.
- `getNextSibling`: Return a reference to the next child in the list of siblings.

Each AST node is considered to have a list of children, some text, and a "token type". Trees are self-similar in that a tree node is also a tree. An AST is defined completely as:

```

/** Minimal AST node interface used by ANTLR AST generation
 * and tree-walker.
 */
public interface AST {
    /** Add a (rightmost) child to this node */
    public void addChild(AST c);
    public boolean equals(AST t);
    public boolean equalsList(AST t);
    public boolean equalsListPartial(AST t);
    public boolean equalsTree(AST t);
    public boolean equalsTreePartial(AST t);
    public ASTEnumeration findAll(AST tree);
    public ASTEnumeration findAllPartial(AST subtree);
    /** Get the first child of this node; null if no children */
    public AST getFirstChild();
    /** Get the next sibling in line after this one */
    public AST getNextSibling();
}
  
```

```

    /** Get the token text for this node */
    public String getText();
    /** Get the token type for this node */
    public int getType();
    /** Get number of children of this node; if leaf, returns 0 */
    public int getNumberOfChildren();
    public void initialize(int t, String txt);
    public void initialize(AST t);
    public void initialize(Token t);
    /** Set the first child of a node. */
    public void setFirstChild(AST c);
    /** Set the next sibling after this one. */
    public void setNextSibling(AST n);
    /** Set the token text for this node */
    public void setText(String text);
    /** Set the token type for this node */
    public void setType(int ttype);
    public String toString();
    public String toStringList();
    public String toStringTree();
}

```

Tree grammar rules

As with the SORCERER tool of PCCTS 1.33 and the ANTLR token grammars, tree grammars are collections of EBNF rules embedded with actions, semantic predicates, and syntactic predicates.

```

rule:  alternative1
      |  alternative2
      . . .
      |  alternativen
      ;

```

Each alternative production is composed of a list of elements where an element can be one of the items in a regular ANTLR grammar with the addition of the tree pattern element, which has the form:

```

#( root-token child1 child2 ... childn )

```

For example, the following tree pattern matches a simple PLUS-rooted tree with two INT children:=

```

#( PLUS INT INT )

```

The root of a tree pattern must be a token reference, but the children elements can even be subrules. For example, a common structure is an if-then-else tree where the else-clause statement subtree is optional:

```

#( IF expr stat (stat)? )

```

An important thing to remember when specifying tree patterns and tree grammars in general is that sufficient matches are done not exact matches. As long as the tree satisfies the pattern, a match is reported, regardless of how much is left unparsed. For example, #(A B) will report a match for any larger tree with the same structure such as #(A #(B C) D).

Syntactic predicates

ANTLR tree parsers use only a single symbol of lookahead, which is normally not a problem as intermediate forms are explicitly designed to be easy to walk. However, there is occasionally the need to distinguish between similar tree structures. Syntactic predicates can be used to overcome the limitations of limited fixed lookahead. For example, distinguishing between the unary and binary minus operator is best done by using operator nodes of differing token types, but given the same root node, a syntactic predicate can be used to distinguish between these structures:

```
expr:  ( #(MINUS expr expr) )=> #( MINUS expr expr )
      |  #( MINUS expr )
      ...
      ;
```

The order of evaluation is very important as the second alternative is a "subset" of the first alternative.

Semantic predicates

Semantic predicates at the start of an alternative are simply incorporated into the alternative prediction expressions as with a regular grammar. Semantic predicates in the middle of productions throw exceptions when they evaluate to false just like a regular grammar.

An Example Tree Walker

Consider how you would build a simple calculator. One approach would be to build a parser that computed expression values as it recognized the input. For the purposes of illustration, we will build a parser that constructs a tree intermediate representation of the input expression and a tree parser that walks the intermediate representation, computing the result.

Our recognizer, `CalcParser`, is defined via the following grammar.

```
class CalcParser extends Parser;
options {
    buildAST = true;    // uses CommonAST by default
}

expr:  mexpr (PLUS^ mexpr)* SEMI!
      ;

mexpr
  :   atom (STAR^ atom)*
      ;

atom:  INT
      ;
```

The `PLUS` and `STAR` tokens are considered operators and, hence, subtree roots; they are annotated with the `^` character. The `SEMI` token reference is suffixed with the `!` character to indicate it should not be included in the tree.

The scanner for this calculator is defined as follows:

```
class CalcLexer extends Lexer;

WS      :      ( ' '
              |  '\t'
              |  '\n'
              |  '\r' )
              { _ttype = Token.SKIP; }
      ;
```

```

LPAREN: '('
      ;

RPAREN: ')'
      ;

STAR:   '*'
      ;

PLUS:   '+'
      ;

SEMI:   ';'
      ;

INT     :      ('0'..'9')+
      ;

```

The trees generated by this recognizer are simple expression trees. For example, input "3*4+5" results in a tree of the form `#(+ (* 3 4) 5)`. In order to build a tree walker for trees of this form, you have to describe its structure recursively to ANTLR:

```

class CalcTreeWalker extends TreeParser;

expr      :      #(PLUS expr expr)
          |      #(STAR expr expr)
          |      INT
          ;

```

Once the structure has been specified, you are free to embed actions to compute the appropriate result. An easy way to accomplish this is to have the `expr` rule return an integer result and then have each alternative compute the subresult for each subtree. The following tree grammar and actions produces the desired effect:

```

class CalcTreeWalker extends TreeParser;

expr returns [int r]
{
    int a,b;
    r=0;
}
:      #(PLUS a=expr b=expr) {r = a+b;}
|      #(STAR a=expr b=expr) {r = a*b;}
|      i:INT                  {r = Integer.parseInt(i.getText());}
;

```

Notice that no precedence specification is necessary when computing the result of an expression--the structure of the tree encodes this information. That is why intermediate trees are much more than copies of the input in tree form. The input symbols are indeed stored as nodes in the tree, but the structure of the input is encoded as the relationship of those nodes.

The code needed to launch the parser and tree walker is:

```

import java.io.*;
import antlr.CommonAST;
import antlr.collections.AST;

class Calc {
    public static void main(String[] args) {

```

```

try {
    CalcLexer lexer =
        new CalcLexer(new DataInputStream(System.in));
    CalcParser parser = new CalcParser(lexer);
    // Parse the input expression
    parser.expr();
    CommonAST t = (CommonAST)parser.getAST();
    // Print the resulting tree out in LISP notation
    System.out.println(t.toStringList());
    CalcTreeWalker walker = new CalcTreeWalker();
    // Traverse the tree created by the parser
    int r = walker.expr(t);
    System.out.println("value is "+r);
} catch(Exception e) {
    System.err.println("exception: "+e);
}
}
}

```

Transformations

While tree parsers are useful to examine trees or generate output from a tree, they must be augmented to handle tree transformations. ANTLR tree parsers support the `buildAST` option just like regular parsers; this is analogous to the transform mode of SORCERER. Without programmer intervention, the tree parser will automatically copy the input tree to a result tree. Each rule has an implicit (automatically defined) result tree; the result tree of the start symbol can be obtained from the tree parser via the `getAST` method. The various alternatives and grammar elements may be annotated with "!" to indicate that they should not be automatically linked into the output tree. Portions of, or entire, subtrees may be rewritten.

Actions embedded within the rules can set the result tree based upon tests and tree constructions. See the section on [grammar action translations](#).

An Example Tree Transformation

Revisiting the simple `Calc` example from above, we can perform a few tree transformations instead of computing the expression value. The action in the following tree grammar optimizes away the addition identity operation (addition to zero).

```

class CalcTreeWalker extends TreeParser;
options{
    buildAST = true;    // "transform" mode
}

expr:! #(PLUS left:expr right:expr)
// '!' turns off auto transform
{
    // x+0 = x
    if ( #right.getType()==INT &&
        Integer.parseInt(#right.getText())==0 )
    {
        #expr = #left;
    }
    // 0+x = x
    else if ( #left.getType()==INT &&
             Integer.parseInt(#left.getText())==0 )
    {
        #expr = #right;
    }
}

```

```

        // x+y
        else {
            #expr = #(PLUS, left, right);
        }
    }
    | #(STAR expr expr) // use auto transformation
    | i:INT
;

```

The code to launch the parser and tree transformer is:

```

import java.io.*;
import antlr.CommonAST;
import antlr.collections.AST;

class Calc {
    public static void main(String[] args) {
        try {
            CalcLexer lexer =
                new CalcLexer(new DataInputStream(System.in));
            CalcParser parser = new CalcParser(lexer);
            // Parse the input expression
            parser.expr();
            CommonAST t = (CommonAST)parser.getAST();
            // Print the resulting tree out in LISP notation
            System.out.println(t.toLispString());

            CalcTreeWalker walker = new CalcTreeWalker();
            // Traverse the tree created by the parser
            walker.expr(t);
            // Get the result tree from the walker
            t = (CommonAST)walker.getAST();
            System.out.println(t.toLispString());
        } catch (Exception e) {
            System.err.println("exception: "+e);
        }
    }
}

```

Examining/Debugging ASTs

Often when developing a tree parser, you will get parse errors. Unfortunately, your trees are usually very large, making it difficult to determine where your AST structure error is. To help the situation (I found it VERY useful when building the Java tree parser), I created an `ASTFrame` class (a `JFrame`) that you can use to view your ASTs in a Swing tree view. It does not copy the tree, but uses a `TreeModel`. Run `antlr.debug.misc.ASTFrame` as an application to test it out or see the new Java grammar `Main.java`. I am not sure it will live in the same package as I'm not sure how debugging etc... will shake out with future ANTLR versions. Here is a simple example usage:

```

public static void main(String args[]) {
    // Create the tree nodes
    ASTFactory factory = new ASTFactory();
    CommonAST r = (CommonAST)factory.create(0, "ROOT");
    r.addChild((CommonAST)factory.create(0, "C1"));
    r.addChild((CommonAST)factory.create(0, "C2"));
    r.addChild((CommonAST)factory.create(0, "C3"));

    ASTFrame frame = new ASTFrame("AST JTree Example", r);
    frame.setVisible(true);
}

```

}

Version: \$Id: //depot/code/org antlr/release/antlr-2.7.3/doc/sor.html#1 \$



Latest version is 2.7.3.

Download now! »



[Home](#)

[Download](#)

[News](#)

[Using ANTLR](#)

[Documentation](#)

[FAQ](#)

[Articles](#)

[Grammars](#)

[File Sharing](#)

[Code API](#)

[Tech Support](#)

[About ANTLR](#)

[What is ANTLR](#)

[Why use ANTLR](#)

[Showcase](#)

[Testimonials](#)

[Getting Started](#)

[Software License](#)

[ANTLR WebLogs](#)

[StringTemplate](#)

[TML](#)

[PCCTS](#)

SEARCH

ANTLR Specification: Token Streams

Token Streams

Traditionally, a lexer and parser are tightly coupled objects; that is, one does not imagine anything sitting between the parser and the lexer, modifying the stream of tokens. However, language recognition and translation can benefit greatly from treating the connection between lexer and parser as a *token stream*. This idea is analogous to Java I/O streams, where you can pipeline lots of stream objects to produce highly-processed data streams.

Introduction

ANTLR identifies a stream of Token objects as any object that satisfies the `TokenStream` interface (prior to 2.6, this interface was called `Tokenizer`); i.e., any object that implements the following method.

```
Token nextToken();
```

Graphically, a normal stream of tokens from a lexer (producer) to a parser (consumer) might look like the following at some point during the parse.

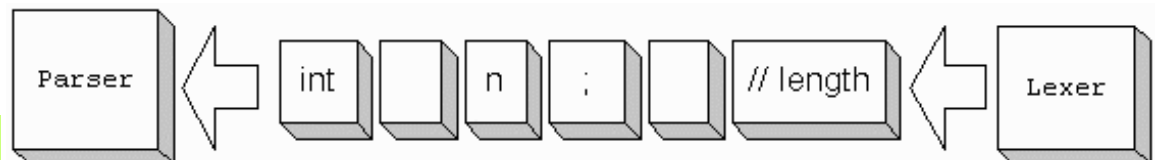

The most common token stream is a lexer, but once you imagine a physical stream between the lexer and parser, you start imagining interesting things that you can do. For example, you can:

- filter a stream of tokens to strip out unwanted tokens
- insert imaginary tokens to help the parser recognize certain nasty structures
- split a single stream into multiple streams, sending certain tokens of interest down the various streams
- multiplex multiple token streams onto one stream, thus, "simulating" the lexer states of tools like PCCTS, lex, and so on.

The beauty of the token stream concept is that parsers and lexers are not affected--they are merely consumers and producers of streams. Stream objects are filters that produce, process, combine, or separate token streams for use by consumers. Existing lexers and parsers may be combined in new and interesting ways without modification.

This document formalizes the notion of a token stream and describes in detail some very useful stream filters.

Pass-Through Token Stream

A token stream is any object satisfying the following interface.

```
public interface TokenStream {
    public Token nextToken()
        throws java.io.IOException;
}
```

For example, a "no-op" or pass-through filter stream looks like:

```
import antlr.*;
import java.io.IOException;

class TokenStreamPassThrough
    implements TokenStream {
    protected TokenStream input;

    /** Stream to read tokens from */
    public TokenStreamPassThrough(TokenStream in) {
        input = in;
    }

    /** This makes us a stream */
    public Token nextToken() throws IOException {
        return input.nextToken(); // "short circuit"
    }
}
```

You would use this simple stream by having it pull tokens from the lexer and then have the parser pull tokens from it as in the following main() program.

```
public static void main(String[] args) {
    MyLexer lexer =
        new MyLexer(new DataInputStream(System.in));
    TokenStreamPassThrough filter =
        new TokenStreamPassThrough(lexer);
    MyParser parser = new MyParser(filter);
    parser.startRule();
}
```

Token Stream Filtering

Most of the time, you want the lexer to discard whitespace and comments, however, what if you also want to reuse the lexer in situations where the parser must see the comments? You can design a single lexer to cover many situations by having the lexer emit comments and whitespace along with the normal tokens. Then, when you want to discard whitespace, put a filter between the lexer and the parser to kill whitespace tokens.

ANTLR provides `TokenStreamBasicFilter` for such situations. You can instruct it to discard any token type or types without having to modify the lexer. Here is an example usage of `TokenStreamBasicFilter` that filters out comments and whitespace.

```
public static void main(String[] args) {
    MyLexer lexer =
        new MyLexer(new DataInputStream(System.in));
    TokenStreamPassThrough filter =
        new TokenStreamPassThrough(lexer);
    filter.discard(MyParser.WS);
    filter.discard(MyParser.COMMENT);
    MyParser parser = new MyParser(filter);
    parser.startRule();
}
```

Note that it is more efficient to have the lexer immediately discard lexical structures you do not want because you do not have to construct a Token object. On the other hand, filtering the stream leads to more flexible lexers.

Token Stream Splitting

Sometimes you want a translator to ignore but not discard portions of the input during the recognition phase. For example, you want to ignore comments vis-a-vis parsing, but you need the comments for

translation. The solution is to send the comments to the parser on a *hidden* token stream--one that the parser is not "listening" to. During recognition, actions can then examine the hidden stream or streams, collecting the comments and so on. Stream-splitting filters are like prisms that split white light into rainbows.

The following diagram illustrates a situation in which a single stream of tokens is split into three.

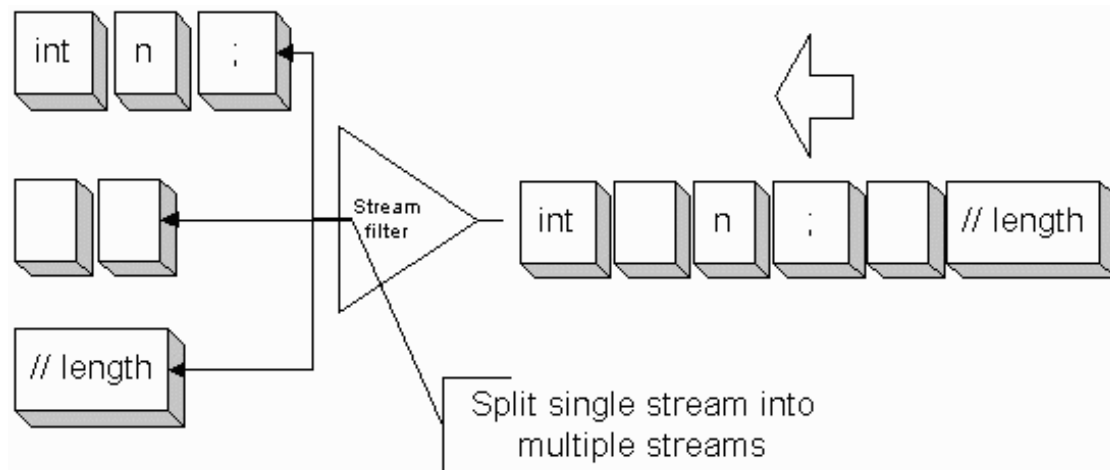

You would have the parser pull tokens from the topmost stream.

There are many possible capabilities and implementations of a stream splitter. For example, you could have a "Y-splitter" that actually duplicated a stream of tokens like a cable-TV Y-connector. If the filter were thread-safe and buffered, you could have multiple parsers pulling tokens from the filter at the same time.

This section describes a stream filter supplied with ANTLR called `TokenStreamHiddenTokenFilter` that behaves like a coin sorter, sending pennies to one bin, dimes to another, etc... This filter splits the input stream into two streams, a main stream with the majority of the tokens and a *hidden* stream that is buffered so that you can ask it questions later about its contents. Because of the implementation, however, you cannot attach a parser to the hidden stream. The filter actually weaves the hidden tokens among the main tokens as you will see below.

Example

Consider the following simple grammar that reads in integer variable declarations.

```
decls: (decl)+
      ;
decl : begin:INT ID end:SEMI
      ;
```

Now assume input:

```
int n; // list length
/** doc */
int f;
```

Imagine that whitespace is ignored by the lexer and that you have instructed the filter to split comments onto the hidden stream. Now if the parser is pulling tokens from the main stream, it will see only "INT ID SEMI FLOAT ID SEMI" even though the comments are hanging around on the hidden stream. So the parser effectively ignores the comments, but your actions can query the filter for tokens on the hidden stream.

The first time through rule `decl`, the `begin` token reference has no hidden tokens before or after, but

```
filter.getHiddenAfter(end)
```

returns a reference to token

```
// list length
```

which in turn provides access to

```
/** doc */
```

The second time through decl

```
filter.getHiddenBefore(begin)
```

refers to the

```
/** doc */
```

comment.

Filter Implementation

The following diagram illustrates how the Token objects are physically weaved together to simulate two different streams.

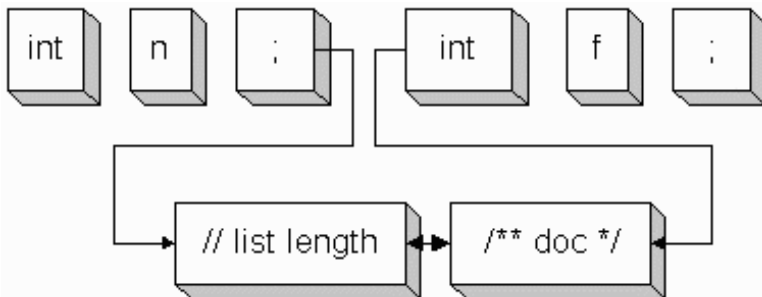

As the tokens are consumed, the `TokenStreamHiddenTokenFilter` object hooks the hidden tokens to the main tokens via linked list. There is only one physical `TokenStream` of tokens emanating from this filter and the interweaved pointers maintain sequence information.

Because of the extra pointers required to link the tokens together, you must use a special token object called `CommonHiddenStreamToken` (the normal object is called `CommonToken`). Recall that you can instruct a lexer to build tokens of a particular class with

```
lexer.setTokenObjectClass("classname");
```

Technically, this exact filter functionality could be implemented without requiring a special token object, but this filter implementation is extremely efficient and it is easy to tell the lexer what kind of tokens to create. Further, this implementation makes it very easy to automatically have tree nodes built that preserve the hidden stream information.

This filter affects the lazy-consume of ANTLR. After recognizing every main stream token, the `TokenStreamHiddenTokenFilter` must grab the next `Token` to see if it is a hidden token. Consequently, the use of this filter is not be very workable for interactive (e.g., command-line) applications.

How To Use This Filter

To use `TokenStreamHiddenTokenFilter`, all you have to do is:

- Create the lexer and tell it to create token objects augmented with links to hidden tokens.

```
MyLexer lexer = new MyLexer(some-input-stream);
lexer.setTokenObjectClass(
    "antlr.CommonHiddenStreamToken"
);
```

- Create a `TokenStreamHiddenTokenFilter` object that pulls tokens from the lexer.

```
TokenStreamHiddenTokenFilter filter =
    new TokenStreamHiddenTokenFilter(lexer);
```

- Tell the `TokenStreamHiddenTokenFilter` which tokens to hide, and which to discard. For example,

```
filter.discard(MyParser.WS);
filter.hide(MyParser.SL_COMMENT);
```

- Create a parser that pulls tokens from the `TokenStreamHiddenTokenFilter` rather than the lexer.

```
MyParser parser = new MyParser(filter);
try {
    parser.startRule(); // parse as usual
}
catch (Exception e) {
    System.err.println(e.getMessage());
}
```

See the ANTLR fieldguide entry on [preserving whitespace](#) for a complete example.

Tree Construction

Ultimately, hidden stream tokens are needed during the translation phase, which normally means while tree walking. How do we pass the hidden stream info to the translator without mucking up the tree grammar? Easy: use AST nodes that save the hidden stream tokens. ANTLR defines `CommonASTWithHiddenTokens` for you that hooks the hidden stream tokens onto the tree nodes automatically; methods are available to access the hidden tokens associated with a tree node. All you have to do is tell the parser to create nodes of this node type rather than the default `CommonAST`.

```
parser.setASTNodeClass("antlr.CommonASTWithHiddenTokens");
```

Tree nodes are created as functions of Token objects. The `initialize()` method of the tree node is called with a Token object when the `ASTFactory` creates the tree node. Tree nodes created from tokens with hidden tokens before or after will have the same hidden tokens. You do not have to use this node definition, but it works for many translation tasks:

```
package antlr;

/** A CommonAST whose initialization copies
 * hidden token information from the Token
 * used to create a node.
 */
public class CommonASTWithHiddenTokens
    extends CommonAST {
    // references to hidden tokens
    protected Token hiddenBefore, hiddenAfter;

    public CommonHiddenStreamToken getHiddenAfter() {
        return hiddenAfter;
    }
    public CommonHiddenStreamToken getHiddenBefore() {
```

```

        return hiddenBefore;
    }
    public void initialize(Token tok) {
        CommonHiddenStreamToken t =
            (CommonHiddenStreamToken)tok;
        super.initialize(t);
        hiddenBefore = t.getHiddenBefore();
        hiddenAfter  = t.getHiddenAfter();
    }
}

```

Notice that this node definition assumes that you are using `CommonHiddenStreamToken` objects. A runtime class cast except occurs if you do not have the lexer create `CommonHiddenStreamToken` objects.

Garbage Collection Issues

By partitioning up the input stream and preventing hidden stream tokens from referring to main stream tokens, GC is allowed to work on the Token stream. In the integer declaration example above, when there are no more references to the first SEMI token and the second INT token, the comment tokens are candidates for garbage collection. If all tokens were linked together, a single reference to any token would prevent GC of any tokens. This is not the case in ANTLR's implementation.

Notes

This filter works great for preserving whitespace and comments during translation, but is not always the best solution for handling comments in situations where the output is very dissimilar to the input. For example, there may be 3 comments interspersed within an input statement that you want to combine at the head of the output statement during translation. Rather than having to ask each parsed token for the comments surrounding it, it would be better to have a real, physically-separate stream that buffered the comments and a means of associating groups of parsed tokens with groups of comment stream tokens. You probably want to support questions like *"give me all of the tokens on the comment stream that originally appeared between this beginning parsed token and this ending parsed token."*

This filter implements the exact same functionality as JavaCC's *special* tokens. Sriram Sankar (father of JavaCC) had a great idea with the special tokens and, at the 1997 [Dr. T's Traveling Parsing Revival and Beer Tasting Festival](#), the revival attendees extended the idea to the more general token stream concept. Now, the JavaCC special token functionality is just another ANTLR stream filter with the bonus that you do not have to modify the lexer to specify which tokens are special.

Token Stream Multiplexing (aka "Lexer states")

Now, consider the opposite problem where you want to combine multiple streams rather than splitting a single stream. When your input contains sections or slices that are radically diverse such as Java and JavaDoc comments, you will find that it is hard to make a single lexer recognize all slices of the input. This is primarily because merging the token definitions of the various slices results in an ambiguous lexical language or allows invalid tokens. For example, "final" may be a keyword in one section, but an identifier in another. Also, "@author" is a valid javadoc tag within a comment, but is invalid in the surrounding Java code.

Most people solve this problem by having the lexer sit in one of multiple states (for example, "reading Java stuff" vs "reading JavaDoc stuff"). The lexer starts out in Java mode and then, upon `"/**"`, switches to JavaDoc mode; `"*/"` forces the lexer to switch back to Java mode.

Multiple Lexers

Having a single lexer with multiple states works, but having multiple lexers that are multiplexed onto the same token stream solves the same problem better because the separate lexers are easier to reuse (no cutting and pasting into a new lexer--just tell the stream multiplexor to switch to it). For example, the JavaDoc lexer could be reused for any language problem that had JavaDoc comments.

ANTLR provides a predefined token stream called `TokenStreamSelector` that lets you switch between multiple lexers. Actions in the various lexers control how the selector switches input streams. Consider the following Java fragment.

```
/** Test.
 * @author Terence
 */
int n;
```

Given two lexers, `JavaLexer` and `JavaDocLexer`, the sequence of actions by the two lexers might look like this:

```
JavaLexer: match JAVADOC_OPEN, switch to JavaDocLexer
JavaDocLexer: match AUTHOR
JavaDocLexer: match ID
JavaDocLexer: match JAVADOC_CLOSE, switch back to JavaLexer
JavaLexer: match INT
JavaLexer: match ID
JavaLexer: match SEMI
```

In the Java lexer grammar, you will need a rule to perform the switch to the JavaDoc lexer (recording on the stack of streams the "return lexer"):

```
JAVADOC_OPEN
:   "/*" {selector.push("doclexer");}
;
```

Similarly, you will need a rule in the JavaDoc lexer to switch back:

```
JAVADOC_CLOSE
:   "*/" {selector.pop();}
;
```

The selector has a stack of streams so the JavaDoc lexer does not need to know who invoked it.

Graphically, the selector combines the two lexer streams into a single stream presented to the parser.

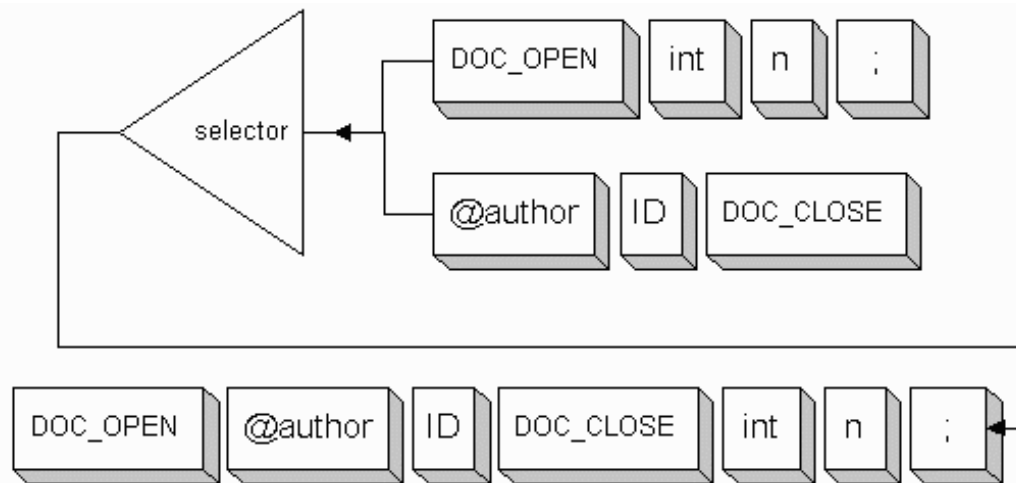

The selector can maintain a list of streams for you so that you can switch to another input stream by name or you can tell it to switch to an actual stream object.

```
public class TokenStreamSelector implements TokenStream {
    public TokenStreamSelector() {...}
    public void addInputStream(TokenStream stream,
        String key) {...}
    public void pop() {...}
    public void push(TokenStream stream) {...}
    public void push(String sname) {...}
}
```

```

/** Set the stream without pushing old stream */
public void select(TokenStream stream) {...}
public void select(String sname)
    throws IllegalArgumentException {...}
}

```

Using the selector is easy:

- Create a selector.

```

TokenStreamSelector selector =
    new TokenStreamSelector();

```

- Name the streams (don't have to name--you can use stream object references instead to avoid the hashtable lookup on each switch).

```

selector.addInputStream(mainLexer, "main");
selector.addInputStream(doclexer, "doclexer");

```

- Select which lexer reads from the char stream first.

```

// start with main java lexer
selector.select("main");

```

- Attach your parser to the selector instead of one of the lexers.

```

JavaParser parser = new JavaParser(selector);

```

Lexers Sharing Same Character Stream

Before moving on to how the parser uses the selector, note that the two lexers have to read characters from the same input stream. Prior to ANTLR 2.6.0, each lexer had its own line number variable, input char stream variable and so on. In order to share the same input state, ANTLR 2.6.0 factors the portion of a lexer dealing with the character input into an object, `LexerSharedInputState`, that can be shared among n lexers (single-threaded). To get multiple lexers to share state, you create the first lexer, ask for its input state object, and then use that when constructing any further lexers that need to share that input state:

```

// create Java lexer
JavaLexer mainLexer = new JavaLexer(input);
// create javadoc lexer; attach to shared
// input state of java lexer
JavaDocLexer doclexer =
    new JavaDocLexer(mainLexer.getInputState());

```

Parsing Multiplexed Token Streams

Just as a single lexer may have trouble producing a single stream of tokens from diverse input slices or sections, a single parser may have trouble handling the multiplexed token stream. Again, a token that is a keyword in one lexer's vocabulary may be an identifier in another lexer's vocabulary. Factoring the parser into separate subparsers for each input section makes sense to handle the separate vocabularies as well as for promoting grammar reuse.

The following parser grammar uses the main lexer token vocabulary (specified with the `importVocab` option) and upon `JAVADOC_OPEN` it creates and invokes a JavaDoc parser to handle the subsequent stream of tokens from within the comment.

```

class JavaParser extends Parser;
options {
    importVocab=Java;
}

input
:    ( (javadoc)? INT ID SEMI )+

```

```

;

javadoc
:   JAVADOC_OPEN
    {
      // create a parser to handle the javadoc comment
      JavaDocParser jdocparser =
        new JavaDocParser(getInputState());
      jdocparser.content(); // go parse the comment
    }
    JAVADOC_CLOSE
;

```

You will note that ANTLR parsers from 2.6.0 also share token input stream state. When creating the "subparser", `JavaParser` tells it to pull tokens from the same input state object.

The JavaDoc parser matches a bunch of tags:

```

class JavaDocParser extends Parser;
options {
    importVocab=JavaDoc;
}

content
:   (   PARAM // includes ID as part of PARAM
      |   EXCEPTION
      |   AUTHOR
      )*
;

```

When the subparser rule `content` finishes, control is naturally returned to the invoking method, `javadoc`, in the Java parser.

The Effect of Lookahead Upon Multiplexed Token Streams

What would happen if the parser needed to look two tokens ahead at the start of the JavaDoc comment? In other words, from the perspective of the main parser, what is the token following `JAVADOC_OPEN`? Token `JAVADOC_CLOSE`, naturally! The main parser treats any JavaDoc comment, no matter how complicated, as a single entity; it does not see into the token stream of the comment nor should it--the subparser handles that stream.

What is the token following the `content` rule in the subparser? "End of file". The analysis of the subparser cannot determine what random method will call it from your code. This is not an issue because there is normally a single token that signifies the termination of the subparser. Even if EOF gets pulled into the analysis somehow, EOF will not be present on the token stream.

Multiple Lexers Versus Calling Another Lexer Rule

Multiple lexer states are also often used to handle very complicated single tokens such as strings with embedded escape characters where input `"\t"` should not be allowed outside of a string. Typically, upon the initial quote, the lexer switches to a "string state" and then switches back to the "normal state" after having matched the guts of the string.

So-called "modal" programming, where your code does something different depending on a mode, is often a bad practice. In the situation of complex tokens, it is better to explicitly specify the complicated token with more rules. Here is the golden rule of when to and when not to use multiplexed token streams:

Complicated single tokens should be matched by calling another (protected) lexer rule whereas streams of tokens from diverse slices or sections should be handled by different lexers multiplexed onto the same stream that feeds the parser.

For example, the definition of a string in a lexer should simply call another rule to handle the nastiness of escape characters:

```

STRING_LITERAL
:   ' ' (ESC | ~(' ' | '\\'))* ' '
;

protected // not a token; only invoked by another rule.
ESC
:   '\\\
    (
      'n'
    |  'r'
    |  't'
    |  'b'
    |  'f'
    |  '"'
    |  '\ '
    |  '\\\ '
    |  ('u')+
      HEX_DIGIT HEX_DIGIT HEX_DIGIT HEX_DIGIT
    ...
    )
;

```

TokenStreamRewriteEngine Easy Syntax-Directed Translation

There are many common situations where you want to tweak or augment a program or data file. ANTLR 2.7.3 introduced a (Java/C# versions only) a very simple but powerful `TokenStream` targeted at the class of problems where:

1. the output language and the input language are similar
2. the relative order of language elements does not change

See the [Syntax Directed TokenStream Rewriting](#) article on the antlr website.

The Future

The ANTLR 2.6 release provides the basic structure for using token streams--future versions will be more sophisticated once we have experience using them.

The current "hidden token" stream filter clearly solves the "ignore but preserve whitespace" problem really well, but it does not handle comments too well in most situations. For example, in real translation problems you want to collect comments at various single tree nodes (like `DECL` or `METHOD`) for interpretation rather than leaving them strewn throughout the tree. You really need a stream splitter that buffers up the comments on a separate stream so you can say "*give me all comments consumed during the recognition of this rule*" or "*give me all comments found between these two real tokens.*" That is almost certainly something you need for translation of comments.

Token streams will lead to fascinating possibilities. Most folks are not used to thinking about token streams so it is hard to imagine what else they could be good for. Let your mind go wild. What about embedded languages where you see slices (aspects) of the input such as Java and SQL (each portion of the input could be sliced off and put through on a different stream). What about parsing Java `.class` files with and without debugging information? If you have a parser for `.class` files without debug info and you want to handle `.class` files with debug info, leave the parser alone and augment the lexer to see the new debug structures. Have a filter split the debug tokens of onto a different stream and the same parser will work for both types of `.class` files.

Later, I would like to add "perspectives", which are really just another way to look at filters. Imagine a raw stream of tokens emanating from a lexer--the root perspective. I can build up a tree of perspectives very easily from there. For example, given a Java program with embedded SQL, you might want multiple perspectives on the input stream for parsing or translation reasons:

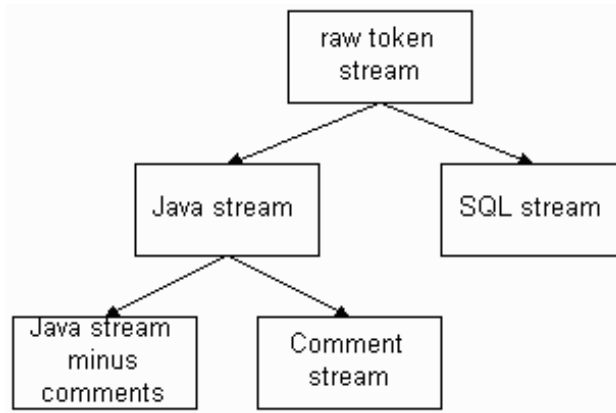

You could attach a parser to the SQL stream or the Java stream minus comments, with actions querying the comment stream.

In the future, I would also like to add the ability of a parser to generate a stream of tokens (or text) as output just like it can build trees now. In this manner, multipass parsing becomes a very natural and simple problem because parsers become stream producers also. The output of one parser can be the input to another.

Version: \$Id: //depot/code/org.antlr/release/antlr-2.7.3/doc/streams.html#3 \$

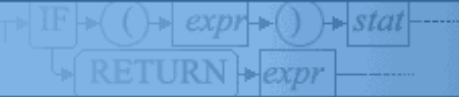

Latest version is 2.7.3.

Download now! »

DOWNLOAD[Home](#)

SEARCH

[Download](#)[News](#)

ANTLR Specification: Vocabularies

[Using ANTLR](#)

Token Vocabularies

[Documentation](#)[FAQ](#)[Articles](#)[Grammars](#)[File Sharing](#)[Code API](#)[Tech Support](#)

Every grammar specifies language structure with rules (substructures) and vocabulary symbols. These symbols are equated with integer "token types" for efficient comparison at run-time. The files that define this mapping from symbol to token type are fundamental to the execution of ANTLR and ANTLR-generated parsers. This document describes the files used and generated by ANTLR plus the options used to control the vocabularies.

Introduction

A parser grammar refers to tokens in its vocabulary by symbol that will correspond to Token objects, generated by the lexer or other token stream, at parse-time. The parser compares a unique integer token type assigned to each symbol against the token type stored in the token objects. If the parser is looking for token type 23, but finds that the first lookahead token's token type, `LT(1).getType()`, is not 23, then the parser throws `MismatchedTokenException`.

A grammar may have an import vocabulary and always has an export vocabulary, which can be referenced by other grammars. Imported vocabularies are never modified and represent the "initial condition" of the vocabulary. Do not confuse importVocabular

The following represent the most common questions:

How does ANTLR decide which vocabulary symbol gets what token type?

Each grammar has a token manager that manages a grammar's export vocabulary. The token manager can be preloaded with symbol / token type pairs by using the grammar `importVocab` option. The option forces ANTLR to look for a file with mappings that look like:

```
PLUS=44
```

Without the `importVocab` option, the grammar's token manager is empty (with one caveat you will see later).

Any token referenced in your grammar that does not have a predefined token type is assigned a type in the order encountered. For example, in the following grammar, tokens A and B will be 4 and 5, respectively:

```
class P extends Parser;
a : A B ;
```

Vocabulary file names are of the form: `NameTokenTypes.txt`.

Why do token types start at 4?

Because ANTLR needs some special token types during analysis. User-defined token types must begin after 3.

[About ANTLR](#)[What is ANTLR](#)[Why use ANTLR](#)[Showcase](#)[Testimonials](#)[Getting Started](#)[Software License](#)[ANTLR WebLogs](#)[StringTemplate](#)[TML](#)[PCCTS](#)

What files associated with vocabulary does ANTLR generate?

ANTLR generates `VTokenTypes.txt` and `VTokenTypes.java` for vocabulary `V` where `V` is either the name of the grammar or specified in an `exportVocab=V` option. The text file is sort of a "freeze-dried" token manager and represents the persistent state needed by ANTLR to allow a grammar in a different file to see a grammar's vocabulary including string literals etc... The Java file is an interface containing the token type constant definitions. Generated parsers implement one of these interfaces to obtain the appropriate token type definitions.

How does ANTLR synchronize the symbol-type mappings between grammars in the same file and in different files?

The export vocabulary for one grammar must become the import vocabulary for another or the two grammars must share a common import vocabulary.

Imagine a parser `P` in `p.g`:

```
// yields PTokenTypes.txt
class P extends Parser;
// options {exportVocab=P;} ---> default!
decl : "int" ID ;
```

and a lexer `L` in `l.g`

```
class L extends Lexer;
options {
  importVocab=P; // reads PTokenTypes.txt
}
ID : ('a'..'z')+ ;
```

ANTLR generates `LTokenTypes.txt` and `LTokenTypes.java` even though `L` is primed with values from `P`'s vocabulary.

Grammars in different files that must share the same token type space should use the `importVocab` option to preload the same vocabulary.

If these grammars are in the same file, ANTLR behaves in exactly same way. However, you can get the two grammars to share the vocabulary (allowing them both to contribute to the same token space) by setting their export vocabularies to the same vocabulary name. For example, with `P` and `L` in one file, you can do the following:

```
// yields PTokenTypes.txt
class P extends Parser;
// options {exportVocab=P;} ---> default!
decl : "int" ID ;

class L extends Lexer;
options {
  exportVocab=P; // shares vocab P
}
ID : ('a'..'z')+ ;
```

If you leave off the `vocab` options from `L`, it will choose to share the first export vocabulary in the file; in this case, it will share `P`'s vocabulary.

```
// yields PTokenTypes.txt
class P extends Parser;
decl : "int" ID ;
```

```
// shares P's vocab
class L extends Lexer;
ID : ('a'..'z')+ ;
```

The token type mapping file looks like this

```
P // exported token vocab name
LITERAL_int="int"=4
ID=5
```

Grammar Inheritance and Vocabularies

Grammars that extend supergrammars inherit rules, actions, and options but what vocabulary does the subgrammar use and what token vocabulary does it use? ANTLR sees the subgrammar as if you had cut and paste all of the nonoverridden rules of the supergrammar into the subgrammar like an include. Therefore, the set of tokens in the subgrammar is the union of the tokens defined in the supergrammar and in the supergrammar. All grammars export a vocabulary file and so the subgrammar will export and use a different vocabulary than the supergrammar. The subgrammar always imports the vocabulary of the supergrammar unless you override it with an `importVocab` option in the subgrammar.

A grammar Q that extends P primes its vocabulary with P's vocabulary as if Q had specified option `importVocab=P`. For example, the following grammar has two token symbols.

```
class P extends Parser;
a : A Z ;
```

The subgrammar, Q, initially has the same vocabulary as the supergrammar, but may add additional symbols.

```
class Q extends P;
f : B ;
```

In this case, Q defines one more symbol, B, yielding a vocabulary for Q of {A,B,C}.

The vocabulary of a subgrammar is always a superset of the supergrammar's vocabulary. Note that overriding rules does not affect the initial vocabulary.

If your subgrammar requires new lexical structures, unused by the supergrammar, you probably need to have the subparser use a sublexer. Override the initial vocabulary with an `importVocab` option that specifies the vocabulary of the sublexer. For example, assume parser P uses PL as a lexer. Without an `importVocab` override, Q's vocabulary would use P's vocab and, consequently, PL's vocabulary. If you would like Q to use token types from another lexer, say QL, do the following:

```
class Q extends P;
options {
    importVocab=QL;
}
f : B ;
```

Q's vocab will now be the same or a superset of QL's vocabulary.

Recognizer Generation Order

If all of your grammars are in one file, you do not have to worry about which grammar file ANTLR should process first, however, you still need to worry about the order in which ANTLR sees the grammars within the file. If you try to import a vocabulary that will be exported by a grammar later in the file, ANTLR will complain that it cannot load the file. The following grammar file will cause antlr to fail:

```

class P extends Parser;
options {
importVocab=L;
}

a : "int" ID;

class L extends Lexer;
ID : 'a';

```

ANTLR will complain that it cannot find LTokenTypes.txt because it has not seen grammar L yet in the grammar file. On the other hand, if you happened to have LTokenTypes.txt lying around (from a previous run of ANTLR on the grammar file when P did not exist?), ANTLR will load it for P and then overwrite it again for L. ANTLR must assume that you want to load a vocabulary generated from another file as it cannot know what grammars are approaching even in the same file.

In general, if you want grammar B to use token types from grammar A (regardless of grammar type), then you must run ANTLR on grammar A first. So, for example, a tree grammar that uses the vocabulary of the parser grammar should be run after ANTLR has generated the parser.

When you want a parser and lexer, for example, to share the same vocabulary space, all you have to do is place them in the same file with their export vocabs pointing at the same place. If they are in separate files, have the parser's import vocab set to the lexer's export vocab unless the parser is contributing lots of literals. In this case, reverse the import/export relationship so the lexer uses the export vocabulary of the parser.

Tricky Vocabulary Stuff

What if your grammars are in separate files and you still want them to share all or part of a token space. There are two solutions: (1) have the grammars import the same vocabulary or (2) have the grammars all inherit from the same base grammar that contains the common token space.

The first solution applies when you have two lexers and two parsers that must parse radically different portions of the input. The example in `examples/java/multiLexer` of the ANTLR 2.6.0 distribution is such a situation. The javadoc comments are parsed with a different lexer/parser than the regular Java portion of the input. The `"*/"` terminating comment lexical structure is necessarily recognized by the javadoc lexer, but it is natural to have the Java parser enclose the launch of the javadoc parser with open/close token references:

```

javadoc
: JAVADOC_OPEN
{
DemoJavaDocParser jdocparser =
new DemoJavaDocParser(getInputState());
jdocparser.content();
}
JAVADOC_CLOSE
;

```

The problem is: the javadoc lexer defines JAVADOC_CLOSE and hence defines its token type. The vocabulary of the Java parser is based upon the Java lexer not the javadoc lexer, unfortunately. To get the javadoc lexer and Java lexer to both see JAVADOC_CLOSE (and have the same token type), have both lexers import a vocabulary file that contains this token type definition. Here are the heads of DemoJavaLexer and DemoJavaDocLexer:

```

class DemoJavaLexer extends Lexer;
options {
importVocab = Common;
}

```

```

...

class DemoJavaDocLexer extends Lexer;
options {
    importVocab = Common;
}
...

```

CommonTokenTypes.txt contains:

```

Common // name of the vocab
JAVADOC_CLOSE=4

```

The second solution to vocabulary sharing applies when you have say one parser and three different lexers (e.g., for various flavors of C). If you only want one parser for space efficiency, then the parser must see the vocabulary of all three lexers and prune out the unwanted structures grammatically (with semantic predicates probably). Given CLexer, GCCLexer, and MSCLexer, make CLexer the supergrammar and have CLexer define the union of all tokens. For example, if MSCLexer needs "_int32" then reserve a token type visible to all lexers in CLexer:

```

tokens {
    INT32;
}

```

In the MSCLexer then, you can actually attach a literal to it.

```

tokens {
    INT32="_int32"
}

```

In this manner, the lexers will all share the same token space allowing you to have a single parser recognize input for multiple C variants.

Version: \$Id: //depot/code/org.antlr/release/antlr-2.7.3/doc/vocab.html#1 \$

[Home](#)

SEARCH

[Download](#)[News](#)

Error Handling and Recovery

[Using ANTLR](#)

Error Handling and Recovery

[Documentation](#)[FAQ](#)[Articles](#)[Grammars](#)[File Sharing](#)[Code API](#)[Tech Support](#)

All syntactic and semantic errors cause parser exceptions to be thrown. In particular, the methods used to match tokens in the parser base class (match et al) throw `MismatchedTokenException`. If the lookahead predicts no alternative of a production in either the parser or lexer, then a `NoViableAltException` is thrown. The methods in the lexer base class used to match characters (match et al) throw analogous exceptions.

ANTLR will generate default error-handling code, or you may specify your own exception handlers. Either case results (where supported by the language) in the creation of a `try/catch` block. Such `try{}` blocks surround the generated code for the grammar element of interest (rule, alternate, token reference, or rule reference). If no exception handlers (default or otherwise) are specified, then the exception will propagate all the way out of the parser to the calling program.

ANTLR's default exception handling is good to get something working, but you will have more control over error-reporting and resynchronization if you write your own exception handlers.

Note that the '@' exception specification of PCCTS 1.33 does not apply to ANTLR.

ANTLR Exception Hierarchy

ANTLR-generated parsers throw exceptions to signal recognition errors or other stream problems. All exceptions derive from `ANTLRException`. The following diagram shows the hierarchy:

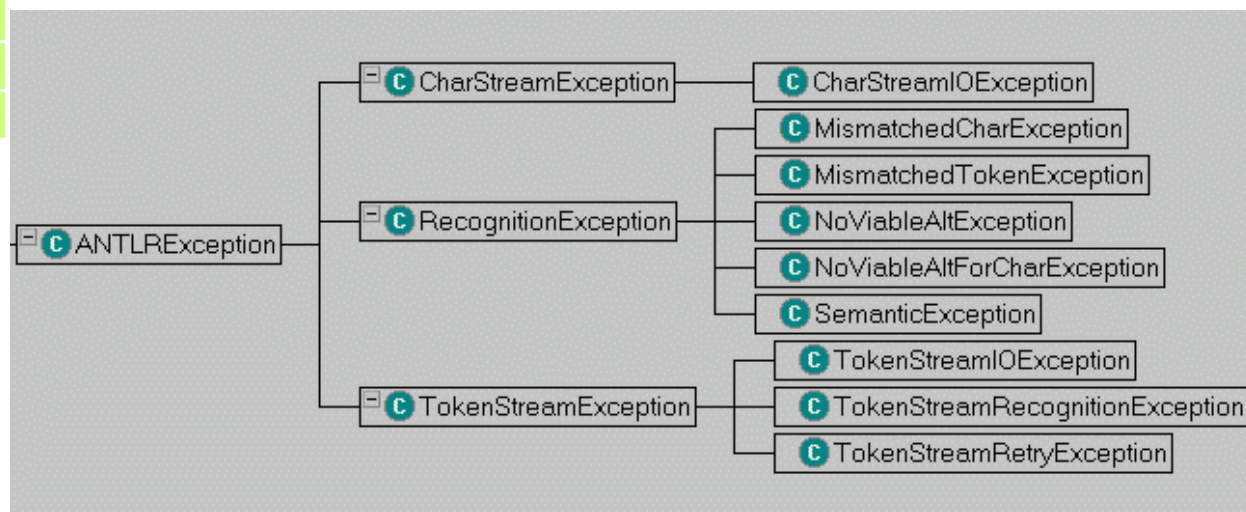
[StringTemplate](#)[TML](#)[PCCTS](#)

Exception

`ANTLRException`

Description

Root of the exception hierarchy. You can directly subclass this if you want to define your own exceptions unless they live more properly under one of the specific exceptions below.

`CharStreamException`

Something bad that happens on the character input stream. Most of the time it will be an IO problem, but you could define an exception for input coming from a dialog box or whatever.

<code>CharStreamIOException</code>	The character input stream had an IO exception (e.g., <code>CharBuffer.fill()</code> can throw this). If <code>nextToken()</code> sees this, it will convert it to a <code>TokenStreamIOException</code> .
<code>RecognitionException</code>	A generic recognition problem with the input. Use this as your "catch all" exception in your <code>main()</code> or other method that invokes a parser, lexer, or treeparser. All parser rules throw this exception.
<code>MismatchedCharException</code>	Thrown by <code>CharScanner.match()</code> when it is looking for a character, but finds a different one on the input stream.
<code>MismatchedTokenException</code>	Thrown by <code>Parser.match()</code> when it is looking for a token, but finds a different one on the input stream.
<code>NoViableAltException</code>	The parser finds an unexpected token; that is, it finds a token that does not begin any alternative in the current decision.
<code>NoViableAltForCharException</code>	The lexer finds an unexpected character; that is, it finds a character that does not begin any alternative in the current decision.
<code>SemanticException</code>	Used to indicate syntactically valid, but nonsensical or otherwise bogus input was found on the input stream. This exception is thrown automatically by failed, validating semantic predicates such as:

```
a : A {false}? B ;
```

ANTLR generates:

```
match(A);
if (!(false)) throw new
    SemanticException("false");
match(B);
```

You can throw this exception yourself during the parse if one of your actions determines that the input is wacked.

<code>TokenStreamException</code>	Indicates that something went wrong while generating a stream of tokens.
<code>TokenStreamIOException</code>	Wraps an <code>IOException</code> in a <code>TokenStreamException</code>
<code>TokenStreamRecognitionException</code>	Wraps a <code>RecognitionException</code> in a <code>TokenStreamException</code> so you can pass it along on a stream.
<code>TokenStreamRetryException</code>	Signals aborted recognition of current token. Try to get one again. Used by <code>TokenStreamSelector.retry()</code> to force <code>nextToken()</code> of stream to re-enter and retry. See the examples/java/includeFile directory.

This a great way to handle nested include files and so on or to try out multiple grammars to see which appears to fit the data. You can have something listen on a socket for multiple input types without knowing which type will show up when.

The typical main or parser invoker has try-catch around the invocation:

```
try {
```

```

    ...
}
catch(TokenStreamException e) {
    System.err.println("problem with stream: "+e);
}
catch(RecognitionException re) {
    System.err.println("bad input: "+re);
}

```

Lexer rules throw `RecognitionException`, `CharStreamException`, and `TokenStreamException`.

Parser rules throw `RecognitionException` and `TokenStreamException`.

Modifying Default Error Messages With Paraphrases

The name or definition of a token in your lexer is rarely meaningful to the user of your recognizer or translator. For example, instead of seeing

```
T.java:1:9: expecting ID, found ';'

```

you can have the parser generate:

```
T.java:1:9: expecting an identifier, found ';'

```

ANTLR provides an easy way to specify a string to use in place of the token name. In the definition for ID, use the paraphrase option:

```

ID
options {
    paraphrase = "an identifier";
}
: ('a'..'z'|'A'..'Z'|'_' )
  ('a'..'z'|'A'..'Z'|'_'|'0'..'9')*
;

```

Note that this paraphrase goes into the token types text file (ANTLR's persistence file). In other words, a grammar that uses this vocabulary will also use the paraphrase.

Parser Exception Handling

ANTLR generates recursive-descent recognizers. Since recursive-descent recognizers operate by recursively calling the rule-matching methods, this results in a call stack that is populated by the contexts of the recursive-descent methods. Parser exception handling for grammar rules is a lot like exception handling in a language like C++ or Java. Namely, when an exception is thrown, the normal thread of execution is stopped, and functions on the call stack are exited sequentially until one is encountered that wants to catch the exception. When an exception is caught, execution resumes at that point.

In ANTLR, parser exceptions are thrown when (a) there is a syntax error, (b) there is a failed validating semantic predicate, or (c) you throw a parser exception from an action.

In all cases, the recursive-descent functions on the call stack are exited until an exception handler is encountered for that exception type or one of its base classes (in non-object-oriented languages, the hierarchy of exception types is not implemented by a class hierarchy). Exception handlers arise in one of two ways. First, if you do nothing, ANTLR will generate a default exception handler for every parser rule. The default exception handler will report an error, sync to the follow set of the rule, and return from that rule. Second, you may specify your own exception handlers in a variety of ways, as described later.

If you specify an exception handler for a rule, then the default exception handler is not generated for that rule. In addition, you may control the generation of default exception handlers with a [per-grammar or per-rule option](#).

Specifying Parser Exception-Handlers

You may attach exception handlers to a rule, an alternative, or a labeled element. The general form for specifying an exception handler is:

```
exception [label]
catch [exceptionType exceptionVariable]
    { action }
catch ...
catch ...
```

where the label is only used for attaching exceptions to labeled elements. The `exceptionType` is the exception (or class of exceptions) to catch, and the `exceptionVariable` is the variable name of the caught exception, so that the action can process the exception if desired. Here is an example that catches an exception for the rule, for an alternate and for a labeled element:

```
rule:    a:A B C
        |    D E
          exception // for alternate
            catch [RecognitionException ex] {
              reportError(ex.toString());
            }
        ;
        exception // for rule
        catch [RecognitionException ex] {
          reportError(ex.toString());
        }
        exception[a] // for a:A
        catch [RecognitionException ex] {
          reportError(ex.toString());
        }
}
```

Note that exceptions attached to alternates and labeled elements **do not** cause the rule to exit. Matching and control flow continues as if the error had not occurred. Because of this, you must be careful not to use any variables that would have been set by a successful match when an exception is caught.

Default Exception Handling in the Lexer

Normally you want the lexer to keep trying to get a valid token upon lexical error. That way, the parser doesn't have to deal with lexical errors and ask for another token. Sometimes you want exceptions to pop out of the lexer--usually when you want to abort the entire parsing process upon syntax error. To get ANTLR to generate lexers that pass on `RecognitionException`'s to the parser as `TokenStreamException`'s, use the `defaultErrorHandler=false` grammar option. Note that IO exceptions are passed back as `TokenStreamIOException`'s regardless of this option.

Here is an example that uses a bogus semantic exception (which is a subclass of `RecognitionException`) to demonstrate blasting out of the lexer:

```
class P extends Parser;
{
public static void main(String[] args) {
    L lexer = new L(System.in);
    P parser = new P(lexer);
    try {
        parser.start();
    }
    catch (Exception e) {
        System.err.println(e);
    }
}
}

start : "int" ID (COMMA ID)* SEMI ;
```

```
class L extends Lexer;
options {
    defaultErrorHandler=false;
}

{int x=1;}

ID : ('a'..'z')+ ;

SEMI: ';'
    {if ( expr )
     throw new
      SemanticException("test",
                        getFilename(),
                        getLine());} ;

COMMA: ',' ;

WS : (' '|'\n'){newline();}+
    {$setType(Token.SKIP);}
    ;
```

When you type in, say, "int b;" you get the following as output:

```
antlr.TokenStreamRecognitionException: test
```

```
Version: $Id: //depot/code/org.antlr/release/antlr-2.7.3/doc/err.html#1 $
```



Latest version is 2.7.3.

Download now! »

DOWNLOAD[Home](#)

SEARCH

[Download](#)[News](#)[Using ANTLR](#)[Documentation](#)[FAQ](#)[Articles](#)[Grammars](#)[File Sharing](#)[Code API](#)[Tech Support](#)[About ANTLR](#)[What is ANTLR](#)[Why use ANTLR](#)[Showcase](#)[Testimonials](#)[Getting Started](#)[Software License](#)[ANTLR WebLogs](#)[StringTemplate](#)[TML](#)[PCCTS](#)

ANTLR Specification: Run-time

Java Runtime Model

Programmer's Interface

In this section, we describe what ANTLR generates after reading your grammar file and how to use that output to parse input. The classes from which your lexer, token, and parser classes are derived are provided as well.

What ANTLR generates

ANTLR generates the following types of files, where *MyParser*, *MyLexer*, and *MyTreeParser* are names of grammar classes specified in the grammar file. You may have an arbitrary number of parsers, lexers, and tree-parsers per grammar file; a separate class file will be generated for each. In addition, token type files will be generated containing the token vocabularies used in the parsers and lexers. One or more token vocabularies may be defined in a grammar file, and shared between different grammars. For example, given the grammar file:

```

class MyParser extends Parser;
options {
  exportVocab=My;
}
... rules ...

class MyLexer extends Lexer;
options {
  exportVocab=My;
}
... rules ...

class MyTreeParser extends TreeParser;
options {
  exportVocab=My;
}
... rules ...
  
```

The following files will be generated:

- *MyParser.java*. The parser with member methods for the parser rules.
- *MyLexer.java*. The lexer with the member methods for the lexical rules.
- *MyTreeParser.java*. The tree-parser with the member methods for the tree-parser rules.
- *MyTokenTypes.java*. An interface containing all of the token types defined by your parsers and lexers using the exported vocabulary named *My*.
- *MyTokenTypes.txt*. A text file containing all of the token types, literals, and paraphrases defined by parsers and lexers contributing vocabulary *My*.

The programmer uses the classes by referring to them:

1. Create a lexical analyzer. The constructor with no arguments implies that you want to read from standard input.
2. Create a parser and attach it to the lexer (or other TokenStream).
3. Call one of the methods in the parser to begin parsing.

If your parser generates an AST, then get the AST value, create a tree-parser, and invoke one of the tree-parser rules using the AST.

```
MyLexer lex = new MyLexer();
MyParser p =
    new MyParser(lex, user-defined-args-if-any);
p.start-rule();
// and, if you are tree parsing the result...
MyTreeParser tp = new MyTreeParser();
tp.start-rule(p.getAST());
```

You can also specify the name of the token and/or AST objects that you want the lexer/parser to create. Java's support of dynamic programming makes this quite painless:

```
MyLexer lex = new MyLexer();
lex.setTokenObjectClass("mypackage.MyToken");
// defaults to "antlr.CommonToken"
...
parser.setASTNodeClass("mypackage.MyASTNode");
// defaults to "antlr.CommonAST"
```

Make sure you give a fully-qualified class name.

The lexer and parser can cause `IOExceptions` as well as `RecognitionExceptions`, which you must catch:

```
CalcLexer lexer =
    new CalcLexer(new DataInputStream(System.in));
CalcParser parser = new CalcParser(lexer);
// Parse the input expression
try {
    parser.expr();
}
catch (IOException io) {
    System.err.println("IOException");
}
catch (RecognitionException e) {
    System.err.println("exception: "+e);
}
```

Multiple Lexers/Parsers With Shared Input State

Occasionally, you will want two parsers or two lexers to share input state; that is, you will want them to pull input from the same source token stream or character stream. The section on [multiple lexer "states"](#) describes such a situation.

ANTLR factors the input variables such as line number, guessing state, input stream, etc... into a separate object so that another lexer or parser could share that state. The `LexerSharedInputState` and `ParserSharedInputState` embody this factoring. Method `getInputState()` can be used on either `CharScanner` or `Parser` objects. Here is how to construct two lexers sharing the same input stream:

```
// create Java lexer
JavaLexer mainLexer = new JavaLexer(input);
// create javadoc lexer; attach to shared
```

```
// input state of java lexer
JavaDocLexer doclexer =
    new JavaDocLexer(mainLexer.getInputState());
```

Parsers with shared input state can be created similarly:

```
JavaDocParser jdocparser =
    new JavaDocParser(getInputState());
jdocparser.content(); // go parse the comment
```

Sharing state is easy, but what happens upon exception during the execution of the "subparser"? What about syntactic predicate execution? It turns out that invoking a subparser with the same input state is exactly the same as calling another rule in the same parser as far as error handling and syntactic predicate guessing are concerned. If the parser is guessing before the call to the subparser, the subparser must continue guessing, right? Exceptions thrown inside the subparser must exit the subparser and return to enclosing error handler or syntactic predicate handler.

Parser Implementation

Parser Class

ANTLR generates a parser class (an extension of `LLkParser`) that contains a method for every rule in your grammar. The general format looks like:

```
public class MyParser extends LLkParser
    implements MyLexerTokenTypes
{
    protected P(TokenBuffer tokenBuf, int k) {
        super(tokenBuf,k);
        tokenNames = _tokenNames;
    }
    public P(TokenBuffer tokenBuf) {
        this(tokenBuf,1);
    }
    protected P(TokenStream lexer, int k) {
        super(lexer,k);
        tokenNames = _tokenNames;
    }
    public P(TokenStream lexer) {
        this(lexer,1);
    }
    public P(ParserSharedInputState state) {
        super(state,1);
        tokenNames = _tokenNames;
    }
    ...
    // add your own constructors here...
    rule-definitions
}
```

Parser Methods

ANTLR generates recursive-descent parsers, therefore, every rule in the grammar will result in a method that applies the specified grammatical structure to the input token stream. The general form of a parser method looks like:

```
public void rule()
    throws RecognitionException,
        TokenStreamException
{
```

```

    init-action-if-present
    if ( lookahead-predicts-production-1 ) {
        code-to-match-production-1
    }
    else if ( lookahead-predicts-production-2 ) {
        code-to-match-production-2
    }
    ...
    else if ( lookahead-predicts-production-n ) {
        code-to-match-production-n
    }
    else {
        // syntax error
        throw new NoViableAltException(LT(1));
    }
}

```

This code results from a rule of the form:

```

rule:  production-1
      | production-2
      ...
      | production-n
      ;

```

If you have specified arguments and a return type for the rule, the method header changes to:

```

/* generated from:
 *   rule(user-defined-args)
 *   returns return-type : ... ;
 */
public return-type rule(user-defined-args)
    throws RecognitionException,
           TokenStreamException
{
    ...
}

```

Token types are integers and we make heavy use of bit sets and range comparisons to avoid excessively-long test expressions.

EBNF Subrules

Subrules are like unlabeled rules, consequently, the code generated for an EBNF subrule mirrors that generated for a rule. The only difference is induced by the EBNF subrule operators that imply optionality or looping.

(...)? optional subrule. The only difference between the code generated for an optional subrule and a rule is that there is no default `else`-clause to throw an exception--the recognition continues on having ignored the optional subrule.

```

{
    init-action-if-present
    if ( lookahead-predicts-production-1 ) {
        code-to-match-production-1
    }
    else if ( lookahead-predicts-production-2 ) {
        code-to-match-production-2
    }
    ...
}

```

```

    else if ( lookahead-predicts-production-n ) {
        code-to-match-production-n
    }
}

```

Not testing the optional paths of optional blocks has the potential to delay the detection of syntax errors.

(...)* **closure subrule**. A closure subrule is like an optional looping subrule, therefore, we wrap the code for a simple subrule in a "forever" loop that exits whenever the lookahead is not consistent with any of the alternative productions.

```

{
    init-action-if-present
loop:
do {
    if ( lookahead-predicts-production-1 ) {
        code-to-match-production-1
    }
    else if ( lookahead-predicts-production-2 ) {
        code-to-match-production-2
    }
    ...
    else if ( lookahead-predicts-production-n ) {
        code-to-match-production-n
    }
    else {
        break loop;
    }
}
while (true);
}

```

While there is no need to explicitly test the lookahead for consistency with the exit path, the grammar analysis phase computes the lookahead of what follows the block. The lookahead of what follows must be disjoint from the lookahead of each alternative otherwise the loop will not know when to terminate. For example, consider the following subrule that is nondeterministic upon token A.

(A | B)* A

Upon A, should the loop continue or exit? One must also ask if the loop should even begin. Because you cannot answer these questions with only one symbol of lookahead, the decision is non-LL(1).

Not testing the exit paths of closure loops has the potential to delay the detection of syntax errors.

As a special case, a closure subrule with one alternative production results in:

```

{
    init-action-if-present
loop:
while ( lookahead-predicts-production-1 ) {
    code-to-match-production-1
}
}

```

This special case results in smaller, faster, and more readable code.

(...)+ **positive closure subrule**. A positive closure subrule is a loop around a series of production prediction tests like a closure subrule. However, we must guarantee that at least one iteration of the loop

is done before proceeding to the construct beyond the subrule.

```

{
  int _cnt = 0;
  init-action-if-present
loop:
  do {
    if ( lookahead-predicts-production-1 ) {
      code-to-match-production-1
    }
    else if ( lookahead-predicts-production-2 ) {
      code-to-match-production-2
    }
    ...
    else if ( lookahead-predicts-production-n ) {
      code-to-match-production-n
    }
    else if ( _cnt>1 ) {
      // lookahead predicted nothing and we've
      // done an iteration
      break loop;
    }
    else {
      throw new NoViableAltException(LT(1));
    }
    _cnt++; // track times through the loop
  }
  while (true);
}

```

While there is no need to explicitly test the lookahead for consistency with the exit path, the grammar analysis phase computes the lookahead of what follows the block. The lookahead of what follows must be disjoint from the lookahead of each alternative otherwise the loop will not know when to terminate. For example, consider the following subrule that is nondeterministic upon token *A*.

(*A* | *B*)+ *A*

Upon *A*, should the loop continue or exit? Because you cannot answer this with only one symbol of lookahead, the decision is non-LL(1).

Not testing the exit paths of closure loops has the potential to delay the detection of syntax errors.

You might ask why we do not have a `while` loop that tests to see if the lookahead is consistent with any of the alternatives (rather than having series of tests inside the loop with a `break`). It turns out that we can generate smaller code for a series of tests than one big one. Moreover, the individual tests must be done anyway to distinguish between alternatives so a `while` condition would be redundant.

As a special case, if there is only one alternative, the following is generated:

```

{
  init-action-if-present
  do {
    code-to-match-production-1
  }
  while ( lookahead-predicts-production-1 );
}

```

Optimization. When there are a large (where large is user-definable) number of strictly LL(1) prediction alternatives, then a `switch`-statement can be used rather than a sequence of `if`-statements. The non-LL(1) cases are handled by generating the usual `if`-statements in the `default` case. For example:

```

switch ( LA(1) ) {
  case KEY_WHILE :
  case KEY_IF :
  case KEY_DO :
    statement();
    break;
  case KEY_INT :
  case KEY_FLOAT :
    declaration();
    break;
  default :
    // do whatever else-clause is appropriate
}

```

This optimization relies on the compiler building a more direct jump (via jump table or hash table) to the *i*th production matching code. This is also more readable and faster than a series of bit set membership tests.

Production Prediction

LL(1) prediction. Any LL(1) prediction test is a simple set membership test. If the set is a singleton set (a set with only one element), then an integer token type == comparison is done. If the set degree is greater than one, a bit set is created and the single input token type is tested for membership against that set. For example, consider the following rule:

```

a : A | b ;
b : B | C | D | E | F;

```

The lookahead that predicts production one is {A} and the lookahead that predicts production two is {B, C, D, E, F}. The following code would be generated by ANTLR for rule *a* (slightly cleaned up for clarity):

```

public void a() {
  if ( LA(1)==A ) {
    match(A);
  }
  else if (token_set1.member(LA(1))) {
    b();
  }
}

```

The prediction for the first production can be done with a simple integer comparison, but the second alternative uses a bit set membership test for speed, which you probably didn't recognize as testing `LA(1).member({B,C,D,E,F})`. The complexity threshold above which bitset-tests are generated is user-definable.

We use arrays of `long ints` (64 bits) to hold bit sets. The *i*th element of a bitset is stored in the word number `i/64` and the bit position within that word is `i % 64`. The divide and modulo operations are extremely expensive and, but fortunately, a strength reduction can be done. Dividing by a power of two is the same as shifting right and modulo a power of two is the same as masking with that power minus one. All of these details are hidden inside the implementation of the `BitSet` class in the package `antlr.collections.impl`.

The various bit sets needed by ANTLR are created and initialized in the generated parser (or lexer) class.

Approximate LL(*k*) prediction. An extension of LL(1)...basically we do a series of up to *k* bit set tests rather than a single as we do in LL(1) prediction. Each decision will use a different amount of lookahead, with LL(1) being the dominant decision type.

Production Element Recognition

Token references. Token references are translated to:

```
match(token-type);
```

For example, a reference to token `KEY_BEGIN` results in:

```
match(KEY_BEGIN);
```

where `KEY_BEGIN` will be an integer constant defined in the `MyParserTokenType` interface generated by ANTLR.

String literal references. String literal references are references to automatically generated tokens to which ANTLR automatically assigns a token type (one for each unique string). String references are translated to:

```
match(T);
```

where `T` is the token type assigned by ANTLR to that token.

Character literal references. Referencing a character literal implies that the current rule is a lexical rule. Single characters, `'t'`, are translated to:

```
match('t');
```

which can be manually inlined with:

```
if ( c=='t' ) consume();
else throw new MismatchedCharException(
    "mismatched char: '"+(char)c+"'");
```

if the method call proves slow (at the cost of space).

Wildcard references. In lexical rules, the wildcard is translated to:

```
consume();
```

which simply gets the next character of input without doing a test.

References to the wildcard in a parser rule results in the same thing except that the `consume` call will be with respect to the parser.

Not operator. When operating on a token, `~T` is translated to:

```
matchNot(T);
```

When operating on a character literal, `'t'` is translated to:

```
matchNot('t');
```

Range operator. In parser rules, the range operator (`T1..T2`) is translated to:

```
matchRange(T1,T2);
```

In a lexical rule, the range operator for characters $c1..c2$ is translated to:

```
matchRange(c1,c2);
```

Labels. Element labels on atom references become `Token` references in parser rules and `ints` in lexical rules. For example, the parser rule:

```
a : id:ID {System.out.println("id is "+id);} ;
```

would be translated to:

```
public void a() {
    Token id = null;
    id = LT(1);
    match(ID);
    System.out.println("id is "+id);
}
```

For lexical rules such as:

```
ID : w:. {System.out.println("w is "+(char)w);} ;
```

the following code would result:

```
public void ID() {
    int w = 0;
    w = c;
    consume(); // match wildcard (anything)
    System.out.println("w is "+(char)w);
}
```

Labels on rule references result in `AST` references, when generating trees, of the form `label_ast`.

Rule references. Rule references become method calls. Arguments to rules become arguments to the invoked methods. Return values are assigned like Java assignments. Consider rule reference `i=list [1]` to rule:

```
list[int scope] returns int
: { return scope+3; }
;
```

The rule reference would be translated to:

```
i = list(1);
```

Semantic actions. Actions are translated verbatim to the output parser or lexer except for the [translations required for AST generation](#) and the following:

- `$FOLLOW(r)`: FOLLOW set name for rule `r`
- `$FIRST(r)`: FIRST set name for rule `r`

Omitting the rule argument implies you mean the current rule. The result type is a `BitSet`, which you can test via `$FIRST(a).member(LBRACK)` etc...

Here is a sample rule:

```
a : A {System.out.println($FIRST(a));} B
```

```

exception
  catch [RecognitionException e] {
    if ( $FOLLOW.member(SEMICOLON) ) {
      consumeUntil(SEMICOLON);
    }
    else {
      consume();
    }
  }
}
;

```

Results in

```

public final void a() throws RecognitionException, TokenStreamException {
  try {
    match(A);
    System.out.println(_tokenSet_0);
    match(B);
  }
  catch (RecognitionException e) {
    if ( _tokenSet_1.member(SEMICOLON) ) {
      consumeUntil(SEMICOLON);
    }
    else {
      consume();
    }
  }
}
}

```

To add members to a lexer or parser class definition, add the class member definitions enclosed in {} immediately following the class specification, for example:

```

class MyParser;
{
  protected int i;
  public MyParser(TokenStream lexer,
    int aUsefulArgument) {
    i = aUsefulArgument;
  }
}
... rules ...

```

ANTLR collects everything inside the {...} and inserts it in the class definition before the rule-method definitions. When generating C++, this may have to be extended to allow actions after the rules due to the wacky ordering restrictions of C++.

Standard Classes

ANTLR constructs parser classes that are subclasses of the `antlr.LLkParser` class, which is a subclass of the `antlr.Parser` class. We summarize the more important members of these classes here. See `Parser.java` and `LLkParser.java` for details of the implementation.

```

public abstract class Parser {
  protected ParserSharedInputState inputState;
  protected ASTFactory ASTFactory;
  public abstract int LA(int i);
  public abstract Token LT(int i);
  public abstract void consume();
  public void consumeUntil(BitSet set) { ... }
  public void consumeUntil(int tokenType) { ... }
}

```

```

    public void match(int t)
        throws MismatchedTokenException { ... }
    public void matchNot(int t)
        throws MismatchedTokenException { ... }
    ...
}

public class LLkParser extends Parser {
    public LLkParser(TokenBuffer tokenBuf, int k_)
        { ... }
    public LLkParser(TokenStream lexer, int k_)
        { ... }
    public int LA(int i) { return input.LA(i); }
    public Token LT(int i) { return input.LT(i); }
    public void consume() { input.consume(); }
    ...
}

```

Lexer Implementation

Lexer Form

The lexers produced by ANTLR are a lot like the parsers produced by ANTLR. They only major differences are that (a) scanners use characters instead of tokens, and (b) ANTLR generates a special `nextToken` rule for each scanner which is a production containing each public lexer rule as an alternate. The name of the lexical grammar class provided by the programmer results in a subclass of `CharScanner`, for example

```

public class MyLexer extends antlr.CharScanner
    implements LTokenTypes, TokenStream
{
    public L(InputStream in) {
        this(new ByteBuffer(in));
    }
    public L(Reader in) {
        this(new CharBuffer(in));
    }
    public L(InputBuffer ib) {
        this(new LexerSharedInputState(ib));
    }
    public L(LexerSharedInputState state) {
        super(state);
        caseSensitiveLiterals = true;
        setCaseSensitive(true);
        literals = new Hashtable();
    }

    public Token nextToken() throws TokenStreamException {
        scanning logic
        ...
    }
    recursive and other non-inlined lexical methods
    ...
}

```

When an ANTLR-generated parser needs another token from its lexer, it calls a method called `nextToken`. The general form of the `nextToken` method is:

```

public Token nextToken()
    throws TokenStreamException {

```

```

int tt;
for (;;) {
    try {
        resetText();
        switch ( c ) {
            case for each char predicting lexical rule
            call lexical rule gets token type -> tt
            default :
                throw new NoViableAltForCharException(
                    "bad char: '"+(char)c+"'");
        }
        if ( tt!=Token.SKIP ) {
            return makeToken(tt);
        }
    }
    catch (RecognitionException ex) {
        reportError(ex.toString());
    }
}
}

```

For example, the lexical rules:

```

lexclass Lex;

WS   : ( '\t' | '\r' | ' ' ) {_ttype=Token.SKIP;} ;
PLUS : '+' ;
MINUS: '-' ;
INT  : ( '0'..'9' )+ ;
ID   : ( 'a'..'z' )+ ;
UID  : ( 'A'..'Z' )+ ;

```

would result in something like:

```

public class Lex extends CharScanner
    implements TTokenTypes {
    ...
    public Token nextToken()
        throws TokenStreamException {
        int _tt = Token.EOF_TYPE;
        for (;;) {
            try {
                resetText();
                switch ( _c ) {
                    case '\t': case '\r': case ' ':
                        _tt=mWS();
                        break;
                    case '+':
                        _tt=mPLUS();
                        break;
                    case '-':
                        _tt=mMINUS();
                        break;
                    case '0': case '1': case '2': case '3':
                    case '4': case '5': case '6': case '7':
                    case '8': case '9':
                        _tt=mINT();
                        break;
                    case 'a': case 'b': case 'c': case 'd':
                    case 'e': case 'f': case 'g': case 'h':
                    case 'i': case 'j': case 'k': case 'l':

```

```

        case 'm': case 'n': case 'o': case 'p':
        case 'q': case 'r': case 's': case 't':
        case 'u': case 'v': case 'w': case 'x':
        case 'y': case 'z':
            _tt=mID();
            break;
        case 'A': case 'B': case 'C': case 'D':
        case 'E': case 'F': case 'G': case 'H':
        case 'I': case 'J': case 'K': case 'L':
        case 'M': case 'N': case 'O': case 'P':
        case 'Q': case 'R': case 'S': case 'T':
        case 'U': case 'V': case 'W': case 'X':
        case 'Y': case 'Z':
            _tt=mUID();
            break;
        case EOF_CHAR :
            _tt = Token.EOF_TYPE;
            break;
        default :
            throw new NoViableAltForCharException(
                "invalid char "+_c);
    }
    if ( _tt!=Token.SKIP ) {
        return makeToken(_tt);
    }
} // try
    catch (RecognitionException ex) {
        reportError(ex.toString());
    }
} // for
}

public int mWS()
    throws RecognitionException,
        CharStreamException,
        TokenStreamException {
    int _ttype = WS;
    switch ( _c ) {
    case '\t':
        match('\t');
        break;
    case '\r':
        match('\r');
        break;
    case ' ':
        match(' ');
        break;
    default :
    {
        throw new NoViableAltForException(
            "no viable for char: "+(char)_c);
    }
    }
    _ttype = Token.SKIP;
    return _ttype;
}

public int mPLUS()
    throws RecognitionException,
        CharStreamException,
        TokenStreamException {
    int _ttype = PLUS;

```

```

        match('+');
        return _ttype;
    }

    public int mMINUS()
        throws RecognitionException,
            CharStreamException,
            TokenStreamException {

        int _ttype = MINUS;
        match('-');
        return _ttype;
    }

    public int mINT()
        throws RecognitionException,
            CharStreamException,
            TokenStreamException {

        int _ttype = INT;
        {
            int _cnt=0;
        _loop:
        do {
            if ( _c>='0' && _c<='9' )
                { matchRange('0','9'); }
            else
                if ( _cnt>=1 ) break _loop;
            else {
                throw new ScannerException(
                    "no viable alternative for char: "+
                    (char)_c);
            }
            _cnt++;
        } while (true);
        }
        return _ttype;
    }

    public int mID()
        throws RecognitionException,
            CharStreamException,
            TokenStreamException {

        int _ttype = ID;
        {
            int _cnt=0;
        _loop:
        do {
            if ( _c>='a' && _c<='z' )
                { matchRange('a','z'); }
            else
                if ( _cnt>=1 ) break _loop;
            else {
                throw new NoViableAltForCharException(
                    "no viable alternative for char: "+
                    (char)_c);
            }
            _cnt++;
        } while (true);
        }
        return _ttype;
    }

```

```

public int mUID()
    throws RecognitionException,
           CharStreamException,
           TokenStreamException {

    int _ttype = UID;
    {
    int _cnt=0;
    _loop:
    do {
        if ( _c>='A' && _c<='Z' )
            { matchRange('A','Z'); }
        else
            if ( _cnt>=1 ) break _loop;
        else {
            throw new NoViableAltForCharException(
                "no viable alternative for char: "+
                (char)_c);
        }
        _cnt++;
    } while (true);
    }
    return _ttype;
}
}

```

ANTLR-generated lexers assume that you will be reading streams of characters. If this is not the case, you must create your own lexer.

Creating Your Own Lexer

To create your own lexer, your Java class that will doing the lexing must implement interface `TokenStream`, which simply states that you must be able to return a stream of tokens via `nextToken`:

```

/**This interface allows any object to
 * pretend it is a stream of tokens.
 * @author Terence Parr, MageLang Institute
 */
public interface TokenStream {
    public Token nextToken();
}

```

ANTLR will not generate a lexer if you do not specify a lexical class.

Launching a parser with a non-ANTLR-generated lexer is the same as launching a parser with an ANTLR-generated lexer:

```

HandBuiltLexer lex = new HandBuiltLexer(...);
MyParser p = new MyParser(lex);
p.start-rule();

```

The parser does not care what kind of object you use for scanning as long as it can answer `nextToken`.

If you build your own lexer, and the token values are also generated by that lexer, then you should inform the ANTLR-generated parsers about the token type values generated by that lexer. Use the [importVocab](#) in the parsers that use the externally-generated token set, and create a token definition file

following the requirements of the `importVocab` option.

Lexical Rules

Lexical rules are essentially the same as parser rules except that lexical rules apply a structure to a series of characters rather than a series of tokens. As with parser rules, each lexical rule results in a method in the output lexer class.

Alternative blocks. Consider a simple series of alternatives within a block:

```
FORMAT : 'x' | 'f' | 'd';
```

The lexer would contain the following method:

```
public int mFORMAT() {
    if ( c=='x' ) {
        match('x');
    }
    else if ( c=='f' ) {
        match('f');
    }
    else if ( c=='d' ) {
        match('d');
    }
    else {
        throw new NoViableAltForCharException(
            "no viable alternative: '"+(char)c+"'");
    }
    return FORMAT;
}
```

The only real differences between lexical methods and grammar methods are that lookahead prediction expressions do character comparisons rather than `LA(i)` comparisons, `match` matches characters instead of tokens, a `return` is added to the bottom of the rule, and lexical methods throw `CharStreamException` objects in addition to `TokenStreamException` and `RecognitionException` objects.

Optimization: Non-Recursive lexical rules. Rules that do not directly or indirectly call themselves can be inlined into the lexer entry method: `nextToken`. For example, the common identifier rule would be placed directly into the `nextToken` method. That is, rule:

```
ID : ( 'a'..'z' | 'A'..'Z' )+
    ;
```

would not result in a method in your lexer class. This rule would become part of the resulting lexer as it would be probably inlined by ANTLR:

```
public Token nextToken() {
    switch ( c ) {
        cases for operators and such here
        case '0': // chars that predict ID token
        case '1':
        case '2':
        case '3':
        case '4':
        case '5':
```

```

case '6':
case '7':
case '8':
case '9':
    while ( c>='0' && c<='9' ) {
        matchRange('0','9');
    }
    return makeToken(ID);
default :
    check harder stuff here like rules
    beginning with a..z
}

```

If not inlined, the method for scanning identifiers would look like:

```

public int mID() {
    while ( c>='0' && c<='9' ) {
        matchRange('0','9');
    }
    return ID;
}

```

where token names are converted to method names by prefixing them with the letter m. The nextToken method would become:

```

public Token nextToken() {
    switch ( c ) {
        cases for operators and such here
    case '0': // chars that predict ID token
    case '1':
    case '2':
    case '3':
    case '4':
    case '5':
    case '6':
    case '7':
    case '8':
    case '9':
        return makeToken(mID());
    default :
        check harder stuff here like rules
        beginning with a..z
    }
}

```

Note that this type of range loop is so common that it should probably be optimized to:

```

while ( c>='0' && c<='9' ) {
    consume();
}

```

Optimization: Recursive lexical rules. Lexical rules that are directly or indirectly recursive are not inlined. For example, consider the following rule that matches nested actions:

```

ACTION
:   '{' ( ACTION | ~'}' ) * '}'
;

```

ACTION would be result in (assuming a character vocabulary of 'a'..'z', '{', '}'):

```

public int mACTION()

```

```

throws RecognitionException,
        CharStreamException,
        TokenStreamException {

int _ttype = ACTION;
match('{');
{
_loop:
do {
    switch ( _c) {
    case '{':
        mACTION();
        break;
    case 'a': case 'b': case 'c': case 'd':
    case 'e': case 'f': case 'g': case 'h':
    case 'i': case 'j': case 'k': case 'l':
    case 'm': case 'n': case 'o': case 'p':
    case 'q': case 'r': case 's': case 't':
    case 'u': case 'v': case 'w': case 'x':
    case 'y': case 'z':
        matchNot('}');
        break;
    default :
        break _loop;
    }
} while (true);
}
match('}');
return _ttype;
}

```

Token Objects

The basic token knows only about a token type:

```

public class Token {
    // constants
    public static final int MIN_USER_TYPE = 3;
    public static final int INVALID_TYPE = 0;
    public static final int EOF_TYPE = 1;
    public static final int SKIP = -1;

    // each Token has at least a token type
    int type=INVALID_TYPE;

    // the illegal token object
    public static Token badToken =
        new Token(INVALID_TYPE, "");

    public Token() {;}
    public Token(int t) { type = t; }
    public Token(int t, String txt) {
        type = t; setText(txt);
    }

    public void setType(int t) { type = t; }
    public void setLine(int l) {;}
    public void setColumn(int c) {;}
    public void setText(String t) {;}

    public int getType() { return type; }
}

```

```

    public int getLine() { return 0; }
    public int getColumn() { return 0; }
    public String getText() {...}
}

```

The raw `Token` class is not very useful. ANTLR supplies a "common" token class that it uses by default, which contains the line number and text associated with the token:

```

public class CommonToken extends Token {
    // most tokens will want line, text information
    int line;
    String text = null;

    public CommonToken() {}
    public CommonToken(String s) { text = s; }
    public CommonToken(int t, String txt) {
        type = t;
        setText(txt);
    }

    public void setLine(int l)    { line = l; }
    public int  getLine()         { return line; }
    public void setText(String s) { text = s; }
    public String getText()       { return text; }
}

```

ANTLR will generate an interface that defines the types of tokens in a token vocabulary. Parser and lexers that share this token vocabulary are generated such that they implement the resulting token types interface:

```

public interface MyLexerTokenTypes {
    public static final int ID = 2;
    public static final int BEGIN = 3;
    ...
}

```

ANTLR defines a token object for use with the `TokenStreamHiddenTokenFilter` object called `CommonHiddenStreamToken`:

```

public class CommonHiddenStreamToken
    extends CommonToken {
    protected CommonHiddenStreamToken hiddenBefore;
    protected CommonHiddenStreamToken hiddenAfter;

    public CommonHiddenStreamToken
        getHiddenAfter() {...}
    public CommonHiddenStreamToken
        getHiddenBefore() {...}
}

```

Hidden tokens are weaved amongst the normal tokens. Note that, for garbage collection reasons, hidden tokens never point back to normal tokens (preventing a linked list of the entire token stream).

Token Lookahead Buffer

The parser must always have fast access to k symbols of lookahead. In a world without syntactic predicates, a simple buffer of k `Token` references would suffice. However, given that even LL(1) ANTLR parsers must be able to backtrack, an arbitrarily-large buffer of `Token` references must be maintained. `LT(i)` looks into the token buffer.

Fortunately, the parser itself does not implement the token-buffering and lookahead algorithm. That is handled by the `TokenBuffer` object. We begin the discussion of lookahead by providing an LL(k) parser framework:

```
public class LLkParser extends Parser {
    TokenBuffer input;
    public int LA(int i) {
        return input.LA(i);
    }
    public Token LT(int i) {
        return input.LT(i);
    }
    public void consume() {
        input.consume();
    }
}
```

All lookahead-related calls are simply forwarded to the `TokenBuffer` object. In the future, some simple caching may be performed in the parser itself to avoid the extra indirection, or ANTLR may generate the call to `input.LT(i)` directly.

The `TokenBuffer` object caches the token stream emitted by the scanner. It supplies `LT()` and `LA()` methods for accessing the k^{th} lookahead token or token type, as well as methods for consuming tokens, guessing, and backtracking.

```
public class TokenBuffer {
    ...
    /** Mark another token for
     * deferred consumption */
    public final void consume() {...}

    /** Get a lookahead token */
    public final Token LT(int i) { ... }

    /** Get a lookahead token value */
    public final int LA(int i) { ... }

    /**Return an integer marker that can be used to
     * rewind the buffer to its current state. */
    public final int mark() { ... }

    /**Rewind the token buffer to a marker.*/
    public final void rewind(int mark) { ... }
}
```

To begin backtracking, a `mark` is issued, which makes the `TokenBuffer` record the current position so that it can rewind the token stream. A subsequent `rewind` directive will reset the internal state to the point before the last `mark`.

Consider the following rule that employs backtracking:

```
stat:    (list EQUAL) => list EQUAL list
        | list
        ;
list:    LPAREN (ID)* RPAREN
        ;
```

Something like the following code would be generated:

```

public void stat()
    throws RecognitionException,
           TokenStreamException
{
    boolean synPredFailed;
    if ( LA(1)==LPAREN ) { // check lookahead
        int marker = tokenBuffer.mark();
        try {
            list();
            match(EQUAL);
            synPredFailed = false;
        }
        catch (RecognitionException e) {
            tokenBuffer.rewind(marker);
            synPredFailed = true;
        }
    }
    if ( LA(1)==LPAREN && !synPredFailed ) {
        // test prediction of alt 1
        list();
        match(EQUAL);
        list();
    }
    else if ( LA(1)==LPAREN ) {
        list();
    }
}

```

The token lookahead buffer uses a circular token buffer to perform quick indexed access to the lookahead tokens. The circular buffer is expanded as necessary to calculate $LT(i)$ for arbitrary i . `TokenBuffer.consume()` does not actually read more tokens. Instead, it defers the read by counting how many tokens have been consumed, and then adjusts the token buffer and/or reads new tokens when `LA()` or `LT()` is called.

Version: \$Id: //depot/code/org.antlr/release/antlr-2.7.3/doc/runtime.html#1 \$

ANTLRLatest version is **2.7.3**.

Download now! »

DOWNLOAD[Home](#)

SEARCH

[Download](#)[News](#)**C++ Notes**

C++ Notes

Using ANTLR[Documentation](#)[FAQ](#)[Articles](#)[Grammars](#)[File Sharing](#)[Code API](#)[Tech Support](#)**About ANTLR**[What is ANTLR](#)[Why use ANTLR](#)[Showcase](#)[Testimonials](#)[Getting Started](#)[Software License](#)[ANTLR WebLogs](#)**StringTemplate****TML****PCCTS**

The C++ runtime and generated grammars look very much the same as the java ones. There are some subtle differences though, but more on this later.

Building the runtime

The following is a bit unix centric. For Windows some contributed project files can be found in lib/cpp/contrib. These may be slightly outdated.

The runtime files are located in the lib/cpp subdirectory of the ANTLR distribution. Building it is in general done via the toplevel configure script and the Makefile generated by the configure script. Before configuring please read the lib/cpp/README file for additional info on specific target machines.

```
./configure --prefix=/usr/local
make
```

Installing ANTLR and the runtime is then done by typing

```
make install
```

This installs the runtime library libantlr.a in /usr/local/lib and the header files in /usr/local/include/antlr. Two convenience scripts antlr and antlr-config are also installed into /usr/local/bin. The first script takes care of invoking antlr and the other can be used to query the right options for your compiler to build files with antlr.

Using the runtime

Generally you will compile the ANTLR generated files with something similar to:

```
c++ -c MyParser.cpp -I/usr/local/include
```

Linking is done with something similar to:

```
c++ -o MyExec <your .o files> -L/usr/local/lib -lantlr
```

Getting ANTLR to generate C++

To get ANTLR to generate C++ code you have to add

```
language="Cpp" ;
```

to the global options section. After that things are pretty much the same as in java mode except that all token and AST classes are wrapped by a reference counting class (this to make live easier (in some ways and much harder in others)). The reference counting class uses

```
operator->
```

to reference the object it is wrapping. As a result of this you use `->` in C++ mode instead of the `!` of java. See the examples in `examples/cpp` for some illustrations.

AST types

New as of ANTLR 2.7.2 is that if you supply the

```
buildAST=true
```

option to a parser then you **have to** set and initialize an `ASTFactory` for the parser and treewalkers that use the resulting AST.

```
ASTFactory my_factory; // generates CommonAST per default..
MyParser parser( some-lexer );
// Do setup from the AST factory repeat this for all parsers using the AST
parser.initializeASTFactory( my_factory );
parser.setASTFactory( &my_factory );
```

In C++ mode it is also possible to override the AST type used by the code generated by ANTLR. To do this you have to do the following:

- Define a custom AST class like the following:

```
#ifndef __MY_AST_H__
#define __MY_AST_H__

#include <antlr/CommonAST.hpp>

class MyAST;

typedef ANTLR_USE_NAMESPACE(antlr)ASTRefCount<MyAST> RefMyAST;

/** Custom AST class that adds line numbers to the AST nodes.
 * easily extended with columns. Filenames will take more work since
 * you'll need a custom token class as well (one that contains the
 * filename)
 */
class MyAST : public ANTLR_USE_NAMESPACE(antlr)CommonAST {
public:
    // copy constructor
    MyAST( const MyAST& other )
    : CommonAST(other)
    , line(other.line)
    {
    }
    // Default constructor
    MyAST( void ) : CommonAST(), line(0) {}
    virtual ~MyAST( void ) {}
    // get the line number of the node (or try to derive it from the child node
    virtual int getLine( void ) const
    {
        // most of the time the line number is not set if the node is a
        // imaginary one. Usually this means it has a child. Refer to the
        // child line number. Of course this could be extended a bit.
        // based on an example by Peter Morling.
        if ( line != 0 )
            return line;
        if( getFirstChild() )
            return ( RefMyAST(getFirstChild())->getLine() );
        return 0;
    }
    virtual void setLine( int l )
    {
        line = l;
    }
};
```

```

}
/** the initialize methods are called by the tree building constructs
 * depending on which version is called the line number is filled in.
 * e.g. a bit depending on how the node is constructed it will have the
 * line number filled in or not (imaginary nodes!).
 */
virtual void initialize(int t, const ANTLR_USE_NAMESPACE(std)string& txt)
{
    CommonAST::initialize(t,txt);
    line = 0;
}
virtual void initialize( ANTLR_USE_NAMESPACE(antlr)RefToken t )
{
    CommonAST::initialize(t);
    line = t->getLine();
}
virtual void initialize( RefMyAST ast )
{
    CommonAST::initialize(ANTLR_USE_NAMESPACE(antlr)RefAST(ast));
    line = ast->getLine();
}
// for convenience will also work without
void addChild( RefMyAST c )
{
    BaseAST::addChild( ANTLR_USE_NAMESPACE(antlr)RefAST(c) );
}
// for convenience will also work without
void setNextSibling( RefMyAST c )
{
    BaseAST::setNextSibling( ANTLR_USE_NAMESPACE(antlr)RefAST(c) );
}
// provide a clone of the node (no sibling/child pointers are copied)
virtual ANTLR_USE_NAMESPACE(antlr)RefAST clone( void )
{
    return ANTLR_USE_NAMESPACE(antlr)RefAST(new MyAST(*this));
}
static ANTLR_USE_NAMESPACE(antlr)RefAST factory( void )
{
    return ANTLR_USE_NAMESPACE(antlr)RefAST(RefMyAST(new MyAST()));
}
private:
    int line;
};
#endif

```

- Tell ANTLR's C++ codegenerator to use your RefMyAST by including the following in the options section of your grammars:

```
ASTLabelType = "RefMyAST";
```

After that you only need to tell the parser before every invocation of a new instance that it should use the AST factory defined in your class. This is done like this:

```

// make factory with default type of MyAST
ASTFactory my_factory( "MyAST", MyAST::factory );
My_Parser parser(lexer);
// make sure the factory knows about all AST types in the parser..
parser.initializeASTFactory(my_factory);
// and tell the parser about the factory..
parser.setASTFactory( &my_factory );

```

After these steps you can access methods/attributes of (Ref)MyAST directly (without typecasting) in parser/treewalker productions.

Forgetting to do a setASTFactory results in a nice SIGSEGV or you OS's equivalent. The default

constructor of ASTFactory initializes itself to generate CommonAST objects.

If you use a 'chain' of parsers/treewalkers then you have to make sure they all share the same AST factory. Also if you add new definitions of ASTnodes/tokens in downstream parsers/treewalkers you have to apply the respective initializeASTFactory methods to this factory.

This all is demonstrated in the examples/cpp/treewalk example.

Using Heterogeneous AST types

This should now (as of 2.7.2) work in C++ mode. With probably some caveats.

The heteroAST example show how to set things up. A short excerpt:

```
ASTFactory ast_factory;

parser.initializeASTFactory(ast_factory);
parser.setASTFactory(&ast_factory);
```

A small excerpt from the generated initializeASTFactory method:

```
void CalcParser::initializeASTFactory( antlr::ASTFactory& factory )
{
    factory.registerFactory(4, "PLUSNode", PLUSNode::factory);
    factory.registerFactory(5, "MULTNode", MULTNode::factory);
    factory.registerFactory(6, "INTNode", INTNode::factory);
    factory.setMaxNodeType(11);
}
```

After these steps ANTLR should be able to decide what factory to use at what time.

Extra functionality in C++ mode.

In C++ mode ANTLR supports some extra functionality to make life a little easier.

Inserting Code

In C++ mode some extra control is supplied over the places where code can be placed in the generated files. These are extensions on the **header** directive. The syntax is:

```
header "<identifier>" { }
```

identifier	where
pre_include_hpp	Code is inserted before ANTLR generated includes in the header file.
post_include_hpp	Code is inserted after ANTLR generated includes in the header file, but outside any generated namespace specifications.
pre_include_cpp	Code is inserted before ANTLR generated includes in the cpp file.
post_include_cpp	Code is inserted after ANTLR generated includes in the cpp file, but outside any generated namespace specifications.

Pacifying the preprocessor

Sometimes various tree building constructs with '#' in them clash with the C/C++ preprocessor. ANTLR's preprocessor for actions is slightly extended in C++ mode to alleviate these pains.

NOTE: At some point I plan to replace the '#' by something different that gives less trouble in C++.

The following preprocessor constructs are not touched. (And as a result you cannot use these as labels for AST

nodes.

- if
- define
- ifdef
- ifndef
- else
- elif
- endif
- warning
- error
- ident
- pragma
- include

As another extra it's possible to escape '#'-signs with a backslash e.g. "\#". As the action lexer sees these they get translated to simple '#' characters.

A template grammar file for C++

```

header "pre_include_hpp" {
    // gets inserted before antlr generated includes in the header file
}
header "post_include_hpp" {
    // gets inserted after antlr generated includes in the header file
    // outside any generated namespace specifications
}

header "pre_include_cpp" {
    // gets inserted before the antlr generated includes in the cpp file
}

header "post_include_cpp" {
    // gets inserted after the antlr generated includes in the cpp file
}

header {
    // gets inserted after generated namespace specifications in the header
    // file. But outside the generated class.
}

options {
    language="Cpp";
    namespace="something";           // encapsulate code in this namespace
    // namespaceStd="std";           // cosmetic option to get rid of long defines
                                    // in generated code
    // namespaceAntlr="antlr";      // cosmetic option to get rid of long defines
                                    // in generated code
    genHashLines = true;           // generated #line's or turn it off.
}

{
    // global stuff in the cpp file
    ...
}
class MyParser extends Parser;
options {
    exportVocab=My;
}
{
    // additional methods and members
    ...
}
... rules ...

```

```
{
    // global stuff in the cpp file
    ...
}
class MyLexer extends Lexer;
options {
    exportVocab=My;
}
{
    // additional methods and members
    ...
}
... rules ...

{
    // global stuff in the cpp file
    ...
}
class MyTreeParser extends TreeParser;
options {
    exportVocab=My;
}
{
    // additional methods and members
    ...
}
... rules ...
```

ANTLR

Latest version is 2.7.3.

Download now! »

DOWNLOAD[Home](#)[Download](#)[News](#)[Using ANTLR](#)[Documentation](#)[FAQ](#)[Articles](#)[Grammars](#)[File Sharing](#)[Code API](#)[Tech Support](#)[About ANTLR](#)[What is ANTLR](#)[Why use ANTLR](#)[Showcase](#)[Testimonials](#)[Getting Started](#)[Software License](#)[ANTLR WebLogs](#)[StringTemplate](#)[TML](#)[PCCTS](#)

SEARCH

Notes for using the ANTLR 2.7.3 C# Code Generator

C# Code Generator for ANTLR 2.7.3

With the release of ANTLR 2.7.3, you can now generate your Lexers, Parsers and TreeParsers in the ECMA-standard C# language developed by Microsoft. This feature extends the benefits of ANTLR's predicated-LL(k) parsing technology to applications and components running on the [Microsoft .NET platform](#) (and ultimately the [Mono](#) and [dotGNU](#) open-source C#/CLI platforms when they have matured appropriately).

To be able to build and use the C# language Lexers, Parsers and TreeParsers, you will need to link to the ANTLR C# runtime library. The C# runtime model is based on the existing runtime models for [Java](#) and [C++](#) and is thus immediately familiar. The C# runtime and the Java runtime in particular are very similar although there a number of subtle (and not so subtle) differences. Some of these result from differences in the respective runtime environments.

ANTLR C# support was contributed (and is be maintained) by Kunle Odutola, Micheal Jordan and Anthony Oguntimehin.

Building the ANTLR C# Runtime

The ANTLR C# runtime source and build files are located in the `lib/csharp` subdirectory of the ANTLR distribution. This sub-directory is known as the **ANTLR C# runtime directory**. The first step in building the ANTLR C# runtime library is to ensure that ANTLR has been properly installed and built. This process is described in the ANTLR Installation Guide that comes with the distribution. Once ANTLR has been properly built, the ANTLR C# runtime can be built using any one of two distinct methods:

- Using the [Microsoft Visual Studio .NET](#) development tool.

A Visual Studio.NET solution file named `antlr.net-runtime-2.7.3.sln` is provided in the ANTLR C# runtime directory. This allows you to build the ANTLR C# runtime library and test it with a semi-complex grammar. The solution file references two Visual Studio .NET project files:

- `lib/csharp/antlr.runtime.build` - for the ANTLR C# runtime library itself and,
- `examples/csharp/JavaParser.csproj` - for the Java grammar project located within the ANTLR C# examples directory tree.

- Using the freely available [NAnt](#) build tool.

A build file named `antlr.runtime.build` is located in the ANTLR C# runtime directory. To build the ANTLR C# runtime, run

```
nant build
```

from a command shell in the ANTLR C# runtime directory. You can also run

```
nant release nant docs
```

to build a release version and documentation in `lib/csharp/release`.

All the example grammars located in the ANTLR C# examples directory - `examples\csharp` are also supplied with a NAnt build file. Once the ANTLR C# library has been built, you can test it by running

```
nant
```

from a command shell in any of the example directories.

Specifying Code Generation

You can instruct ANTLR to generate your Lexers, Parsers and TreeParsers using the C# code generator by adding the following entry to the global options section at the beginning of your grammar file.

```
{
    language = "CSharp";
}
```

After that things are pretty much the same as in the default **java** code generation mode. See the examples in `examples/csharp` for some illustrations.

- TIP: If you are new to NAnt, ANTLR or the .NET platform, you might want to build your ANTLR projects with something similar to the NANT build files used for the C# examples.

C#-Specific ANTLR Options

- **header - specify additional using directives**

You can instruct the ANTLR C# code generator to include additional using directives in your generated Lexer/Parser/TreeParser by listing the directives within the header section which must be the first section at the beginning of your ANTLR grammar file. *Please note that using directives are the only source code elements that can currently be safely included in the header section for C# code generation.*

```
header
{
    using SymbolTable = kunle.parser.SymbolTable;
    using kunle.compiler;
```

}

- **namespace - specify an enclosing C# Namespace**

You can instruct the ANTLR C# code generator to place your Lexer/Parser/TreeParser in a specific C# namespace by adding a namespace option to either the global options section at the beginning of your ANTLR grammar file or, to the grammar options section for individual Lexers/Parsers/TreeParsers.

```
{
  namespace = "kunle.smalltalk.parser";
}
```

A Template C# ANTLR Grammar File

```
header
{
  // gets inserted in the C# source file before any
  // generated namespace declarations
  // hence -- can only be using directives
}

options {
  language = "CSharp";
  namespace = "something"; // encapsulate code in this namespace
  classHeaderPrefix = "protected"; // use to specify access level for generated class
}

{
  // global code stuff that will be included in the source file just before the 'MyParser'
  class below
  ...
}
class MyParser extends Parser;
options {
  exportVocab=My;
}
{
  // additional methods and members for the generated 'MyParser' class
  ...
}

... generated RULES go here ...

{
  // global code stuff that will be included in the source file just before the 'MyLexer'
  class below
  ...
```

```
}
class MyLexer extends Lexer;
options {
    exportVocab=My;
}
{
    // additional methods and members for the generated 'MyParser' class
    ...
}

... generated RULES go here ...

{
    // global code stuff that will be included in the source file just before the
    'MyTreeParser' class below
    ...
}
class MyTreeParser extends TreeParser;
options {
    exportVocab=My;
}
{
    // additional methods and members for the generated 'MyParser' class
    ...
}

... generated RULES go here ...
```

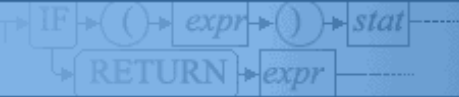
ANTLR

Latest version is 2.7.3.

Download now! »

DOWNLOAD[Home](#)

SEARCH

[Download](#)[News](#)

ANTLR Tree Construction

ANTLR Tree Construction

[Using ANTLR](#)[Documentation](#)[FAQ](#)[Articles](#)[Grammars](#)[File Sharing](#)[Code API](#)[Tech Support](#)

ANTLR helps you build intermediate form trees, or abstract syntax trees (ASTs), by providing grammar annotations that indicate what tokens are to be treated as subtree roots, which are to be leaves, and which are to be ignored with respect to tree construction. As with PCCTS 1.33, you may manipulate trees using tree grammar actions.

It is often the case that programmers either have existing tree definitions or need a special physical structure, thus, preventing ANTLR from specifically defining the implementation of AST nodes. ANTLR specifies only an interface describing minimum behavior. Your tree implementation must implement this interface so ANTLR knows how to work with your trees. Further, you must tell the parser the name of your tree nodes or provide a tree "factory" so that ANTLR knows how to create nodes with the correct type (rather than hardcoding in a `new AST()` expression everywhere). ANTLR can construct and walk any tree that satisfies the AST interface. A number of common tree definitions are provided. Unfortunately, ANTLR cannot parse XML DOM trees since our method names conflict (e.g., `getFirstChild()`); ANTLR was here first <wink>. Argh!

[About ANTLR](#)[What is ANTLR](#)[Why use ANTLR](#)[Showcase](#)[Testimonials](#)[Getting Started](#)[Software License](#)[ANTLR WebLogs](#)

Notation

In this and other documents, tree structures are represented by a LISP-like notation, for example:

```
#(A B C)
```

is a tree with A at the root, and children B and C. This notation can be nested to describe trees of arbitrary structure, for example:

```
#(A B #(C D E))
```

is a tree with A at the root, B as a first child, and an entire subtree as the second child. The subtree, in turn, has C at the root and D,E as children.

Controlling AST construction

AST construction in an ANTLR Parser, or AST transformation in a Tree-Parser, is turned on and off by the [buildAST option](#).

From an AST construction and walking point of view, ANTLR considers all tree nodes to look the same (i. e., they appear to be homogeneous). Through a tree factory or by specification, however, you can instruct ANTLR to create nodes of different types. See the section below on heterogeneous trees.

Grammar annotations for building ASTs

Leaf nodes

ANTLR assumes that any nonsuffixed token reference or token-range is a leaf node in the resulting tree for the enclosing rule. If no suffixes at all are specified in a grammar, then a Parser will construct a

[StringTemplate](#)[TML](#)[PCCTS](#)

linked-list of the tokens (a degenerate AST), and a Tree-Parser will copy the input AST.

Root nodes

Any token suffixed with the "^" operator is considered a root token. A tree node is constructed for that token and is made the root of whatever portion of the tree has been built

```
a : A B^ C^ ;
```

results in tree `#(C #(B A))`.

First A is matched and made a lonely child, followed by B which is made the parent of the current tree, A. Finally, C is matched and made the parent of the current tree, making it the parent of the B node. Note that the same rule without any operators results in the flat tree `A B C`.

Turning off standard tree construction

Suffix a token reference with "!" to prevent incorporation of the node for that token into the resulting tree (the AST node for the token is still constructed and may be referenced in actions, it is just not added to the result tree automatically). Suffix a rule reference "!" to indicate that the tree constructed by the invoked rule should not be linked into the tree constructed for the current rule.

Suffix a rule definition with "!" to indicate that tree construction for the rule is to be turned off. Rules and tokens referenced within that rule still create ASTs, but they are not linked into a result tree. The following rule does no automatic tree construction. Actions must be used to set the return AST value, for example:

```
begin!
  :   INT PLUS i:INT
    { #begin = #(PLUS INT i); }
  ;
```

For finer granularity, prefix alternatives with "!" to shut off tree construction for that alternative only. This granularity is useful, for example, if you have a large number of alternatives and you only want one to have manual tree construction:

```
stat:
  ID EQUALS^ expr    // auto construction
  ... some alternatives ...
  |! RETURN expr
    {#stat = #([IMAGINARY_TOKEN_TYPE] expr);}
  ... more alternatives ...
  ;
```

Tree node construction

With automatic tree construction off (but with `buildAST on`), you must construct your own tree nodes and combine them into tree structures within embedded actions. There are several ways to create a tree node in an action:

1. use `new T(arg)` where `T` is your tree node type and `arg` is either a single token type, a token type and token text, or a `Token`.
2. use `ASTFactory.create(arg)` where `T` is your tree node type and `arg` is either a single token type, a token type and token text, or a `Token`. Using the factory is more general than creating a new node directly, as it defers the node-type decision to the factory, and can be easily changed for the entire grammar.
3. use the shorthand notation `#[TYPE]` or `#[TYPE,"text"]` or `#[TYPE,"text",ASTClassNameToConstruct]`. The shorthand notation results in a call to `ASTFactory.create()` with

- any specified arguments.
- use the shorthand notation `#id`, where `id` is either a token matched in the rule, a label, or a rule-reference.

To construct a tree structure from a set of nodes, you can set the first-child and next-sibling references yourself or call the factory `make` method or use `#(. . .)` notation described below.

AST Action Translation

In parsers and tree parsers with `buildAST` set to true, ANTLR will translate portions of user actions in order to make it easier to build ASTs within actions. In particular, the following constructs starting with '#' will be translated:

`#label`

The AST associated with a labeled token-reference or rule-reference may be accessed as `#label`. The translation is to a variable containing the AST node built from that token, or the AST returned from the rule.

`#rule`

When `rule` is the name of the enclosing rule, ANTLR will translate this into the variable containing the result AST for the rule. This allows you to set the return AST for a rule or examine it from within an action. This can be used when AST generation is on or suppressed for the rule or alternate. For example:

```
r! : a:A      { #r = #a; }
```

Setting the return tree is very useful in combination with normal tree construction because you can have ANTLR do all the work of building a tree and then add an imaginary root node such as:

```
decl : ( TYPE ID )+
      { #decl = #([DECL,"decl"], #decl); }
      ;
```

ANTLR allows you to assign to `#rule` anywhere within an alternative of the rule. ANTLR ensures that references of and assignments to `#rule` within an action force the parser's internal AST construction variables into a stable state. After you assign to `#rule`, the state of the parser's automatic AST construction variables will be set as if ANTLR had generated the tree rooted at `#rule`. For example, any children nodes added after the action will be added to the children of `#rule`.

`#label_in`

In a tree parser, the **input** AST associated with a labeled token reference or rule reference may be accessed as `#label_in`. The translation is to a variable containing the input-tree AST node from which the rule or token was extracted. Input variables are seldom used. You almost always want to use `#label` instead of `#label_in`.

`#id`

ANTLR supports the translation of unlabeled token references as a shorthand notation, as long as the token is unique within the scope of a single alternative. In these cases, the use of an unlabeled token reference identical to using a label. For example, this:

```
r! : A { #r = #A; }
```

is equivalent to:

```
r! : a:A { #r = #a; }
```

`#id_in` is given similar treatment to `#label_in`.

```
#[TOKEN_TYPE] or #[TOKEN_TYPE,"text"] or #[TYPE,"text",
```

ASTClassNameToConstruct]

AST node constructor shorthand. The translation is a call to the `ASTFactory.create()` method. For example, `#[T]` is translated to:

```
ASTFactory.create(T)
```

`#(root, c1, ..., cn)`

AST tree construction shorthand. ANTLR looks for the comma character to separate the tree arguments. Commas within method call tree elements are handled properly; i.e., an element of `"foo(#a,34)"` is ok and will not conflict with the comma separator between the other tree elements in the tree. This tree construct is translated to a "make tree" call. The "make-tree" call is complex due to the need to simulate variable arguments in languages like Java, but the result will be something like:

```
ASTFactory.make(root, c1, ...,
cn);
```

In addition to the translation of the `#(...)` as a whole, the root and each child `c1..cn` will be translated. Within the context of a `#(...)` construct, you may use:

- o `id` or `label` as a shorthand for `#id` or `#label`.
- o `[...]` as a shorthand for `#[...]`.
- o `(...)` as a shorthand for `#(...)`.

The target code generator performs this translation with the help of a special lexer that parses the actions and asks the code-generator to create appropriate substitutions for each translated item. This lexer might impose some restrictions on label names (think of C/C++ preprocessor directives)

Invoking parsers that build trees

Assuming that you have defined a lexer `L` and a parser `P` in your grammar, you can invoke them sequentially on the system input stream as follows.

```
L lexer = new L(System.in);
P parser = new P(lexer);
parser.setASTNodeType("MyAST");
parser.startRule();
```

If you have set `buildAST=true` in your parser grammar, then it will build an AST, which can be accessed via `parser.getAST()`. If you have defined a tree parser called `T`, you can invoke it with:

```
T walker = new T();
walker.startRule(parser.getAST()); // walk tree
```

If, in addition, you have set `buildAST=true` in your tree-parser to turn on transform mode, then you can access the resulting AST of the tree-walker:

```
AST results = walker.getAST();
DumpASTVisitor visitor = new DumpASTVisitor();
visitor.visit(results);
```

Where `DumpASTVisitor` is a predefined `ASTVisitor` implementation that simply prints the tree to the standard output.

You can also use get a LISP-like print out of a tree via

```
String s = parser.getAST().toStringList();
```

AST Factories

ANTLR uses a factory pattern to create and connect AST nodes. This is done to primarily to separate out the tree construction facility from the parser, but also gives you a hook in between the parser and the tree node construction. Subclass `ASTFactory` to alter the `create` methods.

If you are only interested in specifying the AST node type at runtime, use the

```
setASTNodeType(String className)
```

method on the parser or factory. By default, trees are constructed of nodes of type `antlr.CommonAST`. (You must use the fully-qualified class name).

You can also specify a different class name for each token type to generate heterogeneous trees:

```
/** Specify an "override" for the Java AST object created for a
 * specific token. It is provided as a convenience so
 * you can specify node types dynamically. ANTLR sets
 * the token type mapping automatically from the tokens{...}
 * section, but you can change that mapping with this method.
 * ANTLR does it's best to statically determine the node
 * type for generating parsers, but it cannot deal with
 * dynamic values like #[LT(1)]. In this case, it relies
 * on the mapping. Beware differences in the tokens{...}
 * section and what you set via this method. Make sure
 * they are the same.
 *
 * Set className to null to remove the mapping.
 *
 * @since 2.7.2
 */
public void setTokenTypeASTNodeType(int tokenType, String className)
    throws IllegalArgumentException;
```

The `ASTFactory` has some generically useful methods:

```
/** Copy a single node with same Java AST object type.
 * Ignore the tokenType->Class mapping since you know
 * the type of the node, t.getClass(), and doing a dup.
 *
 * clone() is not used because we want all AST creation
 * to go thru the factory so creation can be
 * tracked. Returns null if t is null.
 */
public AST dup(AST t);

/** Duplicate tree including siblings
 * of root.
 */
public AST dupList(AST t);

/** Duplicate a tree, assuming this is a
 * root node of a tree--duplicate that node
 * and what's below; ignore siblings of root
 * node.
 */
public AST dupTree(AST t);
```

Heterogeneous ASTs

Each node in an AST must encode information about the kind of node it is; for example, is it an ADD operator or a leaf node such as an INT? There are two ways to encode this: with a token type or with a Java (or C++ etc...) class type. In other words, do you have a single class type with numerous token types or no token types and numerous classes? For lack of better terms, I (Terence) have been calling ASTs with a single class type *homogeneous* trees and ASTs with many class types *heterogeneous* trees.

The only reason to have a different class type for the various kinds of nodes is for the case where you want to execute a bunch of hand-coded tree walks or your nodes store radically different kinds of data. The example I use below demonstrates an expression tree where each node overrides `value()` so that `root.value()` is the result of evaluating the input expression. From the perspective of building trees and walking them with a generated tree parser, it is best to consider every node as an identical AST node. Hence, the schism that exists between the hetero- and homogeneous AST camps.

ANTLR supports both kinds of tree nodes--at the same time! If you do nothing but turn on the "buildAST=true" option, you get a homogeneous tree. Later, if you want to use physically separate class types for some of the nodes, just specify that in the grammar that builds the tree. Then you can have the best of both worlds--the trees are built automatically, but you can apply different methods to and store different data in the various nodes. Note that the structure of the tree is unaffected; just the type of the nodes changes.

ANTLR applies a "scoping" sort of algorithm for determining the class type of a particular AST node that it needs to create. The default type is `CommonAST` unless, prior to parser invocation, you override that with a call to:

```
myParser.setASTNodeType( "com.acme.MyAST" );
```

where you must use a fully qualified class name.

In the grammar, you can override the default class type by setting the type for nodes created from a particular input token. Use the element option `<AST=typename>` in the `tokens` section:

```
tokens {
    PLUS<AST=PLUSNode>;
    ...
}
```

You may further override the class type by annotating a particular token reference in your parser grammar:

```
anInt : INT<AST=INTNode> ;
```

This reference override is super useful for tokens such as `ID` that you might want converted to a `TYPENAME` node in one context and a `VARREF` in another context.

ANTLR uses the AST factory to create all AST nodes even if it knows the specific type. In other words, ANTLR generates code similar to the following:

```
ANode tmp1_AST = (ANode)astFactory.create(LT(1), "ANode");
```

from

```
a : A<AST=ANode> ;
```

.

An Expression Tree Example

This example includes a parser that constructs expression ASTs, the usual lexer, and some AST node class definitions.

Let's start by describing the AST structure and node types. Expressions have plus and multiply operators and integers. The operators will be subtree roots (nonleaf nodes) and integers will be leaf nodes. For example, input `3+4*5+21` yields a tree with structure:

```
( + ( + 3 ( * 4 5 ) ) 21 )
```

or:

```

+
|
+--21
|
3--*
  |
  4--5

```

All AST nodes are subclasses of `CalcAST`, which are `BaseAST`'s that also answer method `value()`. Method `value()` evaluates the tree starting at that node. Naturally, for integer nodes, `value()` will simply return the value stored within that node. Here is `CalcAST`:

```
public abstract class CalcAST
    extends antlr.BaseAST
{
    public abstract int value();
}
```

The AST operator nodes must combine the results of computing the value of their two subtrees. They must perform a depth-first walk of the tree below them. For fun and to make the operations more obvious, the operator nodes define `left()` and `right()` instead, making them appear even more different than the normal child-sibling tree representation. Consequently, these expression trees can be treated as both homogeneous child-sibling trees and heterogeneous expression trees.

```
public abstract class BinaryOperatorAST extends
    CalcAST
{
    /** Make me look like a heterogeneous tree */
    public CalcAST left() {
        return (CalcAST)getFirstChild();
    }

    public CalcAST right() {
        CalcAST t = left();
        if ( t==null ) return null;
        return (CalcAST)t.getNextSibling();
    }
}
```

The simplest node in the tree looks like:

```
import antlr.BaseAST;
import antlr.Token;
import antlr.collections.AST;
```

```

import java.io.*;

/** A simple node to represent an INT */
public class INTNode extends CalcAST {
    int v=0;

    public INTNode(Token tok) {
        v = Integer.parseInt(tok.getText());
    }

    /** Compute value of subtree; this is
     * heterogeneous part :)
     */
    public int value() {
        return v;
    }

    public String toString() {
        return " "+v;
    }

    // satisfy abstract methods from BaseAST
    public void initialize(int t, String txt) {
    }
    public void initialize(AST t) {
    }
    public void initialize(Token tok) {
    }
}

```

The operators derive from `BinaryOperatorAST` and define `value()` in terms of `left()` and `right()`. For example, here is `PLUSNode`:

```

import antlr.BaseAST;
import antlr.Token;
import antlr.collections.AST;
import java.io.*;

/** A simple node to represent PLUS operation */
public class PLUSNode extends BinaryOperatorAST {
    public PLUSNode(Token tok) {
    }

    /** Compute value of subtree;
     * this is heterogeneous part :)
     */
    public int value() {
        return left().value() + right().value();
    }

    public String toString() {
        return " +";
    }

    // satisfy abstract methods from BaseAST
    public void initialize(int t, String txt) {
    }
    public void initialize(AST t) {
    }
    public void initialize(Token tok) {
    }
}

```

```
}

```

The parser is pretty straightforward except that you have to add the options to tell ANTLR what node types you want to create for which token matched on the input stream. The `tokens` section lists the operators with element option `AST` appended to their definitions. This tells ANTLR to build `PLUSNode` objects for any `PLUS` tokens seen on the input stream, for example. For demonstration purposes, `INT` is not included in the `tokens` section--the specific token references is suffixed with the element option to specify that nodes created from that `INT` should be of type `INTNode` (of course, the effect is the same as there is only that one reference to `INT`).

```
class CalcParser extends Parser;
options {
    buildAST = true; // uses CommonAST by default
}

// define a bunch of specific AST nodes to build.
// can override at actual reference of tokens in
// grammar below.
tokens {
    PLUS<AST=PLUSNode>;
    STAR<AST=MULTNode>;
}

expr:  mexpr (PLUS^ mexpr)* SEMI!
      ;

mexpr
  :   atom (STAR^ atom)*
      ;

// Demonstrate token reference option
atom:  INT<AST=INTNode>
      ;

```

Invoking the parser is done as usual. Computing the value of the resulting AST is accomplished by simply calling method `value()` on the root.

```
import java.io.*;
import antlr.CommonAST;
import antlr.collections.AST;

class Main {
    public static void main(String[] args) {
        try {
            CalcLexer lexer =
                new CalcLexer(
                    new DataInputStream(System.in)
                );
            CalcParser parser =
                new CalcParser(lexer);
            // Parse the input expression
            parser.expr();
            CalcAST t = (CalcAST)parser.getAST();

            System.out.println(t.toStringTree());

            // Compute value and return
            int r = t.value();
            System.out.println("value is "+r);
        } catch(Exception e) {

```

```

                System.err.println("exception: "+e);
                e.printStackTrace();
            }
        }
    }
}

```

For completeness, here is the lexer:

```

class CalcLexer extends Lexer;

WS : (' '
     | '\t'
     | '\n'
     | '\r')
    { $setType(Token.SKIP); }
    ;

LPAREN: '(' ;

RPAREN: ')' ;

STAR: '*' ;

PLUS: '+' ;

SEMI: ';' ;

protected
DIGIT
    : '0'..'9' ;

INT : (DIGIT)+ ;

```

Describing Heterogeneous Trees With Grammars

So what's the difference between this approach and default homogeneous tree construction? The big difference is that you need a tree grammar to describe the expression tree and compute resulting values. But, that's a good thing as it's "executable documentation" and negates the need to handcode the tree parser (the `value()` methods). If you used homogeneous trees, here is all you would need beyond the parser/lexer to evaluate the expressions: [*This code comes from the [examples/java/calc directory](#).*]

```

class CalcTreeWalker extends TreeParser;

expr returns [float r]
{
    float a,b;
    r=0;
}
: #(PLUS a=expr b=expr) {r = a+b;}
| #(STAR a=expr b=expr) {r = a*b;}
| i:INT
  {r = (float)
   Integer.parseInt(i.getText());}
;

```

Because Terence wants you to use tree grammars even when constructing heterogeneous ASTs (to avoid handcoding methods that implement a depth-first-search), implement the following methods in your various heterogeneous AST node class definitions:

```

    /** Get the token text for this node */
    public String getText();
    /** Get the token type for this node */
    public int getType();

```

That is how you can use heterogeneous trees with a tree grammar. Note that your token types must match the `PLUS` and `STAR` token types imported from your parser. I.e., make sure `PLUSNode.getType()` returns `CalcParserTokenTypes.PLUS`. The token types are generated by ANTLR in interface files that look like:

```

public interface CalcParserTokenTypes {
    ...
    int PLUS = 4;
    int STAR = 5;
    ...
}

```

AST (XML) Serialization

[Oliver Zeigermann olli@zeigermann.de provided the initial implementation of this serialization. His [XTAL](#) XML translation code is worth checking out; particularly for reading XML-serialized ASTs back in.]

For a variety of reasons, you may want to store an AST or pass it to another program or computer. Class `antlr.BaseAST` is `Serializable` using the Java code generator, which means you can write ASTs to the disk using the standard Java stuff. You can also write the ASTs out in XML form using the following methods from `BaseAST`:

- `public void xmlSerialize(Writer out)`
- `public void xmlSerializeNode(Writer out)`
- `public void xmlSerializeRootOpen(Writer out)`
- `public void xmlSerializeRootClose(Writer out)`

All methods throw `IOException`.

You can override `xmlSerializeNode` and so on to change the way nodes are written out. By default the serialization uses the class type name as the tag name and has attributes `text` and `type` to store the text and token type of the node.

The output from running the simple heterogeneous tree example, `examples/java/heteroAST`, yields:

```

( + ( + 3 ( * 4 5 ) ) 21 )
<PLUS><PLUS><int>3</int><MULT>
<int>4</int><int>5</int>
</MULT></PLUS><int>21</int></PLUS>
value is 44

```

The LISP-form of the tree shows the structure and contents. The various heterogeneous nodes override the open and close tags and change the way leaf nodes are serialized to use `<int>value</int>` instead of tag attributes of a single node.

Here is the code that generates the XML:

```

Writer w = new OutputStreamWriter(System.out);
t.xmlSerialize(w);
w.write("\n");
w.flush();

```

AST enumerations

The AST `findAll` and `findAllPartial` methods return enumerations of tree nodes that you can walk. Interface

```
antlr.collections.ASTEnumeration
```

and

```
class antlr.Collections.impl.ASTEnumerator
```

implement this functionality. Here is an example:

```
// Print out all instances of
// a-subtree-of-interest
// found within tree 't'.
ASTEnumeration enum;
enum = t.findAll(a-subtree-of-interest);
while ( enum.hasMoreNodes() ) {
    System.out.println(
        enum.nextNode().toStringList()
    );
}
```

A few examples

```
sum :term ( PLUS^ term)*
    ;
```

The "[^]" suffix on the `PLUS` tells ANTLR to create an additional node and place it as the root of whatever subtree has been constructed up until that point for rule `sum`. The subtrees returned by the `term` references are collected as children of the addition nodes. If the subrule is not matched, the associated nodes would not be added to the tree. The rule returns either the tree matched for the first `term` reference or a `PLUS`-rooted tree.

The grammar annotations should be viewed as operators, not static specifications. In the above example, each iteration of the `(...)*` will create a new `PLUS` root, with the previous tree on the left, and the tree from the new `term` on the right, thus preserving the usual associativity for "+".

Look at the following rule that turns off default tree construction.

```
decl!:
    modifiers type ID SEMI;
    { #decl = #([DECL], ID, ([TYPE] type),
                ([MOD] modifiers) ); }
    ;
```

In this example, a declaration is matched. The resulting AST has an "imaginary" `DECL` node at the root, with three children. The first child is the `ID` of the declaration. The second child is a subtree with an imaginary `TYPE` node at the root and the AST from the `type` rule as its child. The third child is a subtree with an imaginary `MOD` at the root and the results of the `modifiers` rule as its child.

Labeled subrules

[THIS WILL NOT BE IMPLEMENTED AS LABELED SUBRULES...We'll do something else eventually.]

In 2.00 ANTLR, each rule has exactly one tree associated with it. Subrules simply add elements to the tree for the enclosing rule, which is normally what you want. For example, expression trees are easily built via:

```
expr: ID ( PLUS^ ID )*
    ;
```

However, many times you want the elements of a subrule to produce a tree that is independent of the rule's tree. Recall that exponents must be computed before coefficients are multiplied in for exponent terms. The following grammar matches the correct syntax.

```
// match exponent terms such as "3*x^4"
eterm
    :   expr MULT ID EXPONENT expr
    ;
```

However, to produce the correct AST, you would normally split the `ID EXPONENT expr` portion into another rule like this:

```
eterm:
    expr MULT^ exp
    ;

exp:
    ID EXPONENT^ expr
    ;
```

In this manner, each operator would be the root of the appropriate subrule. For input `3*x^4`, the tree would look like:

```
 #(MULT 3 #(EXPONENT ID 4))
```

However, if you attempted to keep this grammar in the same rule:

```
eterm
    :   expr MULT^ (ID EXPONENT^ expr)
    ;
```

both `"^"` root operators would modify the same tree yielding

```
 #(EXPONENT #(MULT 3 ID) 4)
```

This tree has the operators as roots, but they are associated with the wrong operands.

Using a labeled subrule allows the original rule to generate the correct tree.

```
eterm
    :   expr MULT^ e:(ID EXPONENT^ expr)
    ;
```

In this case, for the same input `3*x^4`, the labeled subrule would build up its own subtree and make it the operand of the `MULT` tree of the `eterm` rule. The presence of the label alters the AST code generation for the elements within the subrule, making it operate more like a normal rule. Annotations of

"^" make the node created for that token reference the root of the tree for the *e* subrule.

Labeled subrules have a result AST that can be accessed just like the result AST for a rule. For example, we could rewrite the above decl example using labeled subrules (note the use of ! at the start of the subrules to suppress automatic construction for the subrule):

```
decl!:
  m:(! modifiers { #m = #([MOD] modifiers); } )
  t:(! type { #t = #([TYPE] type); } )
  ID
  SEMI;
  { #decl = #([DECL] ID t m ); }
  ;
```

What about subrules that are closure loops? The same rules apply to a closure subrule--there is a single tree for that loop that is built up according to the AST operators annotating the elements of that loop. For example, consider the following rule.

```
term:  T^ i:(OP^ expr)+
      ;
```

For input T OP A OP B OP C, the following tree structure would be created:

```
#(T #(OP #(OP #(OP A) B) C) )
```

which can be drawn graphically as

```
T
|
OP
|
OP--C
|
OP--B
|
A
```

The first important thing to note is that each iteration of the loop in the subrule operates on the same tree. The resulting tree, after all iterations of the loop, is associated with the subrule label. The result tree for the above labeled subrule is:

```
#(OP #(OP #(OP A) B) C)
```

The second thing to note is that, because T is matched first and there is a root operator after it in the rule, T would be at the bottom of the tree if it were not for the label on the subrule.

Loops will generally be used to build up lists of subtree. For example, if you want a list of polynomial assignments to produce a sibling list of ASSIGN subtrees, then the following rule you would normally split into two rules.

```
interp
  :  ( ID ASSIGN poly ";" )+
  ;
```

Normally, the following would be required

```
interp
    :   ( assign )+
    ;
assign
    :   ID ASSIGN^ poly ";"!
    ;
```

Labeling a subrule allows you to write the above example more easily as:

```
interp
    :   ( r:(ID ASSIGN^ poly ";" ) )+
    ;
```

Each recognition of a subrule results in a tree and if the subrule is nested in a loop, all trees are returned as a list of trees (i.e., the roots of the subtrees are siblings). If the labeled subrule is suffixed with a "!", then the tree(s) created by the subrule are not linked into the tree for the enclosing rule or subrule.

Labeled subrules within labeled subrules result in trees that are linked into the surrounding subrule's tree. For example, the following rule results in a tree of the form `X #(A #(B C) D) Y`.

```
a    :   X r:( A^ s:(B^ C) D) Y
    ;
```

Labeled subrules within nonlabeled subrules result in trees that are linked into the surrounding rule's tree. For example, the following rule results in a tree of the form `#(A X #(B C) D Y)`.

```
a    :   X ( A^ s:(B^ C) D) Y
    ;
```

Reference nodes

Not implemented. A node that does nothing but refer to another node in the tree. Nice for embedding the same tree in multiple lists.

Required AST functionality and form

The data structure representing your trees can have any form or type name as long as they implement the AST interface:

```
package antlr.collections;

/** Minimal AST node interface used by ANTLR
 *  AST generation and tree-walker.
 */
public interface AST {
    /** Get the token type for this node */
    public int getType();

    /** Set the token type for this node */
    public void setType(int ttype);

    /** Get the token text for this node */
    public String getText();
```

```

/** Set the token text for this node */
public void setText(String text);

/** Get the first child of this node;
 * null if no children */
public AST getFirstChild();

/** Set the first child of a node */
public void setFirstChild(AST c);

/** Get the next sibling in line after this
 * one
 */
public AST getNextSibling();

/** Set the next sibling after this one */
public void setNextSibling(AST n);

/** Add a (rightmost) child to this node */
public void addChild(AST node);

/** Are two nodes exactly equal? */
public boolean equals(AST t);

/** Are two lists of nodes/subtrees exactly
 * equal in structure and content? */
public boolean equalsList(AST t);

/** Are two lists of nodes/subtrees
 * partially equal? In other words, 'this'
 * can be bigger than 't'
 */
public boolean equalsListPartial(AST t);

/** Are two nodes/subtrees exactly equal? */
public boolean equalsTree(AST t);

/** Are two nodes/subtrees exactly partially
 * equal? In other words, 'this' can be
 * bigger than 't'.
 */
public boolean equalsTreePartial(AST t);

/** Return an enumeration of all exact tree
 * matches for tree within 'this'.
 */
public ASTEnumeration findAll(AST tree);

/** Return an enumeration of all partial
 * tree matches for tree within 'this'.
 */
public ASTEnumeration findAllPartial(
    AST subtree);

/** Init a node with token type and text */
public void initialize(int t, String txt);

/** Init a node using content from 't' */
public void initialize(AST t);

```

```
/** Init a node using content from 't' */
public void initialize(Token t);

/** Convert node to printable form */
public String toString();

/** Treat 'this' as list (i.e.,
 * consider 'this'
 * siblings) and convert to printable
 * form
 */
public String toStringList();

/** Treat 'this' as tree root
 * (i.e., don't consider
 * 'this' siblings) and convert
 * to printable form */
public String toStringTree();
}
```

This scheme does not preclude the use of heterogeneous trees versus homogeneous trees. However, you will need to write extra code to create heterogeneous trees (via a subclass of `ASTFactory`) or by specifying the node types at the token reference sites or in the `tokens` section, whereas the homogeneous trees are free.

Version: \$Id: //depot/code/org.antlr/release/antlr-2.7.3/doc/trees.html#1 \$

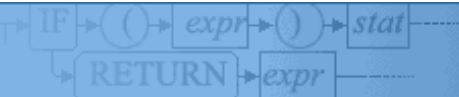

Latest version is 2.7.3.

Download now! »

DOWNLOAD[Home](#)

SEARCH

[Download](#)[News](#)[Using ANTLR](#)

ANTLR Specification: Grammar Inheritance

Grammar Inheritance

[Documentation](#)[FAQ](#)[Articles](#)[Grammars](#)[File Sharing](#)[Code API](#)[Tech Support](#)

Object-oriented programming languages such as C++ and Java allow you to define a new object as it differs from an existing object, which provides a number of benefits. "Programming by difference" saves development/testing time and future changes to the *base* or *superclass* are automatically propagated to the *derived* or *subclass*.

Introduction and motivation

Allowing the ANTLR programmer to define a new grammar as it differs from an existing grammar provides significant benefits. Development time goes down because the programmer only has to specify the rules that are different or that need to be added. Further, when the base grammar changes, all derived grammars will automatically reflect the change. Grammar inheritance is also an interesting way to change the behavior of an existing grammar. A rule or set of rules can be respecified with the same structure, but with different actions.

The most obvious use of grammar inheritance involves describing multiple dialects of the same language. Previous solutions would require multiple grammar versions or a single grammar that recognized all dialects at once (using semantics to constrain the input to a single dialect). With grammar inheritance, one could write a base grammar for the common components and then have a derived grammar for each dialect. Code sharing would occur at the grammar and output parser class level.

Consider a simple subset of English:

```

class PrimarySchoolEnglish;

sentence
  :   subject predicate
  ;
subject
  :   NOUN
  ;
predicate
  :   VERB
  ;
  
```

This grammar recognizes sentences like: `Dilbert speaks.`

To extend this grammar to include sentences manageable by most American college students, we might add direct objects to the definition of a sentence. Rather than copying and modifying the `PrimarySchoolEnglish` grammar, we can simply extend it:

```

class AmericanCollegeEnglish extends
  PrimarySchoolEnglish;

sentence
  :   subject predicate object
  ;
  
```

[StringTemplate](#)[TML](#)[PCCTS](#)

```

object
  :   PREPOSITION ARTICLE NOUN
  ;

```

This grammar describes sentences such as `Dilbert speaks to a dog`. While this looks trivial to implement (just add the appropriate `extends` clause in Java to the output parser class), it involves grammar analysis to preserve grammatical correctness. For example, to generate correct code, ANTLR needs to pull in the base grammar and modify it according to the overridden rules. To see this, consider the following grammar for a simple language:

```

class Simple;

stat:   expr ASSIGN expr
      |   SEMICOLON
      ;

expr:   ID
      ;

```

Clearly, the `ID` token is the lookahead set that predicts the recognition of the first alternative of `stat`. Now, examine a derived dialect of `Simple`:

```

class Derived extends Simple;

expr:   ID
      |   INT
      ;

```

In this case, `{ ID, INT }` predicts the first alternative of `stat`. Unfortunately, a derived grammar affects the recognition of rules inherited from the base grammar! ANTLR must not only override `expr` in `Derived`, but it must override `stat`.

Determining which rules in the base grammar are affected is not easy, so our implementation simply makes a copy of the base grammar and generates a whole new parser with the appropriate modifications. From the programmer's perspective, code/grammar sharing would have occurred, however, from an implementation perspective a copy of the base grammar would be made.

Functionality

Grammar `Derived` inherits from Grammar `Base` all of the rules, options, and actions of `Base` including formal/actual rule parameters and rule actions. `Derived` may override any option or rule and specify new options, rules, and member action. The subgrammar does not inherit actions outside of classes or file options. Consider rule `Base` defined as:

```

class Base extends Parser;
options {
  k = 2;
}
{
  int count = 0;
}
a : A B {an-action}
  | A C
  ;
c : C
  ;

```

A new grammar may be derived as follows:

```

class Derived extends Base;
options {
    k = 3;          // need more lookahead; override
    buildAST=true; // add an option
}
{
    int size = 0; // override; no 'count' def here
}
a : A B {an-action}
  | A C {an-extra-action}
  | Z          // add an alt to rule a
  ;
b : a
  | A B D      // requires LL(3)
  ;

```

ANTLR will actually interpret the subgrammar as if you had typed:

```

class Derived extends Parser;
options {
    k=3;
    buildAST=true;
}
{
    int size = 0; // override Base action
}
a : A B {an-action}
  | A C {an-extra-action}
  | Z          // add an alt to rule a
  ;

b : a
  | A B D      // requires LL(3)
  ;

// inherited from grammar Base
c : C
  ;

```

Rules may be overridden to change their signatures such as their parameters or return types:

```

class Base extends Parser;
a[int x] returns [int y]
  : A
  ;

```

```

class Derived extends Base;
a[float z]
  : A
  ;

```

ANTLR will generate a warning, however:

```
warning: rule Derived.a has different signature than Base.a
```

Because of this ability, the subgrammars do not actually inherit, in the Java-sense, from the supergrammar. Different signatures on the generated methods would prevent the parser from compiling.

Where Are Those Supergrammars?

The set of potential "supergrammars" available to some grammar P includes any other grammar in the same file as P and any listed on the ANTLR command line with

```
-glib f1.g;f2.g
```

where the files must include path names if they are located in another directory.

How is supergrammar P found? The grammars defined in the supergrammar list are read in and an inheritance hierarchy is constructed; any repeated grammar definition in this is ignored. The grammars in the normally specified grammar file are also included in the hierarchy. Incomplete hierarchies results in an error message from ANTLR. Grammars in the same file as P are given precedence to those obtained from other files.

The type of grammar (Lexer,Parser,TreeParser) is determined by the type of the highest grammar in the inheritance chain.

Error Messages

ANTLR generates a file called `expandedT.g`, given a grammar input file (not the `-glib` files) called `T.g`. All error messages are relative to this as you really want to see the whole grammar when dealing with ambiguities etc... In the future, we may have a better solution.

Version: \$Id: //depot/code/org.antlr/release/antlr-2.7.3/doc/inheritance.html#1 \$



Latest version is 2.7.3.

Download now! »

DOWNLOAD[Home](#)

SEARCH

[Download](#)[News](#)

ANTLR Options

Options

File, Grammar, and Rule Options

Rather than have the programmer specify a bunch of command-line arguments to the parser generator, an options section within the grammar itself serves this purpose. This solution is preferable because it associates the required options with the grammar rather than ANTLR invocation. The section is preceded by the `options` keyword and contains a series of option/value assignments surrounded by curly braces such as:

```
options {
  k = 2;
  tokenVocabulary = IDL;
  defaultErrorHandler = false;
}
```

The options section for an entire (.g) file, if specified, immediately follows the (optional) file header:

```
header { package X; }
options { language="FOO"; }
```

The options section for a grammar, if specified, must immediately follow the ';' of the class specifier:

```
class MyParser extends Parser;
options { k=2; }
```

The options section for a rule, if specified, must immediately follow the rule name:

```
myrule[args] returns [retval]
  options { defaultErrorHandler=false; }
  : // body of rule...
  ;
```

The option names are not keywords in ANTLR, but rather are entries in a symbol table examined by ANTLR. The scope of option names is limited to the `options` section; identifiers within your grammar may overlap with these symbols.

The only ANTLR options not specified in the `options` section are things that do not vary with the grammar, but rather than invocation of ANTLR itself. The best example is debugging information. Typically, the programmer will want a makefile to change an ANTLR flag indicating a debug or release build.

Options supported in ANTLR

Key for the type column: F=file, G=grammar, R=rule, L=lexer, S=subrule, C=C++ only.

[Documentation](#)[FAQ](#)[Articles](#)[Grammars](#)[File Sharing](#)[Code API](#)[Tech Support](#)

About ANTLR

[What is ANTLR](#)[Why use ANTLR](#)[Showcase](#)[Testimonials](#)[Getting Started](#)[Software License](#)[ANTLR WebLogs](#)[StringTemplate](#)[TML](#)[PCCTS](#)

Symbol	Type	Description
language	F	Set the generated language
k	G	Set the lookahead depth
importVocab	G	Initial grammar vocabulary
exportVocab	G	Vocabulary exported from grammar
testLiterals	LG, LR	Generate literal-testing code
defaultErrorHandler	G,R	Control default exception-handling
greedy	S	False implies you want subrule loop, (..)* and (..)+, to exit when it sees lookahead consistent with what follows the loop.
codeGenMakeSwitchThreshold	G	Control code generation
codeGenBitsetTestThreshold	G	Control code generation
buildAST	G	Set automatic AST construction in Parser (transform mode in Tree-Parser)
analyzerDebug	G	Spit out lots of debugging information while performing grammar analysis.
codeGenDebug	G	Spit out lots of debugging information while doing code generation.
ASTLabelType	G	Specify the type of all user-defined labels, overrides default of AST.
charVocabulary	LG	Set the lexer character vocabulary
interactive	G	Both the lexer and the parser have an interactive option, which defaults to "false". See the parser speed section above.
caseSensitive	LG	Case is ignored when comparing against character and string literals in the lexer. The case of the input stream is maintained when stored in the token objects.
ignore	LR	Specify a lexer rule to use as whitespace between lexical rule atomic elements (chars, strings, and rule references). The grammar analysis and, hence, the lookahead sets are aware of the whitespace references. This is a lexer rule option.

paraphrase	LR	An easy way to specify a string to use in place of the token name during error processing.
<code>caseSensitiveLiterals</code>	LG	Case is ignored when comparing tokens against the literals table.
<code>classHeaderPrefix</code>	G	Replace the usual class prefix ("public" in Java) for the enclosing class definition.
<code>classHeaderSuffix</code>	G	Append a string to the enclosing class definition. In Java, this amounts to a comma-separated list of interfaces that your lexer, parser, or tree walker must implement.
<code>mangleLiteralPrefix</code>	F	Sets the prefix for the token type definitions of literals rather than using the default of "TOKEN_".
warnWhenFollowAmbig	S	Warnings will be printed when the lookahead set of what follows a subrule containing an empty alternative conflicts with a subrule alternative or when the implicit exit branch of a closure loop conflicts with an alternative. The default is true.
<code>generateAmbigWarnings</code>	S	<p>When true, no ambiguity/nondeterminism warning is generated for the decision associated with the subrule. Use this very carefully--you may change the subrule and miss an ambiguity because of the option. Make very sure that the ambiguity you mask is handled properly by ANTLR. ANTLR-generated parsers resolve ambiguous decisions by consuming input as soon as possible (or by choosing the alternative listed first).</p> <p>See the Java and HTML grammars for proper use of this option. A comment should be supplied for each use indicating why it is ok to shut off the warning.</p>
filter	LG	<p>When true, the lexer ignores any input not exactly matching one of the nonprotected lexer rules.</p> <p>When set to a rule name, the filter option using the rule to parse input characters between valid tokens or those tokens of interest.</p>

namespace	FGC	When set, all the C++ code generated is wrapped in the namespace mentioned here.
namespaceStd	FGC	When set, the ANTLR_USE_NAMESPACE(std) macros in the generated C++ code are replaced by this value. This is a cosmetic option that only makes the code more readable. It does not replace this macro in the support C++ files. Note: use this option directly after setting the language to C++.
namespaceAntlr	FGC	When set, the ANTLR_USE_NAMESPACE(antlr) macros in the generated C++ code are replaced by this value. This is a cosmetic option that only makes the code more readable. It does not replace this macro in the support C++ files. Note: use this option directly after setting the language to C++.
genHashLines	FGC	Boolean toggle, when set to 'true' #line <linenumber> "filename" lines are inserted in the generated code so compiler errors/warnings refer the .g files.
noConstructors	FGLC	Boolean toggle, when set to 'true' the default constructors for the generated lexer/parser/treewalker are omitted. The user then has the option to specify them himself (with extra initializers etc.)

language: Setting the generated language

ANTLR supports multiple, installable code generators. Any code-generator conforming to the ANTLR specification may be invoked via the language option. The default language is "Java", but "Cpp" is also supported. The language option is specified at the file-level, for example:

```
header { package zparse; }
options { language="Java"; }
... classes follow ...
```

k: Setting the lookahead depth

You may set the lookahead depth for any grammar (parser, lexer, or tree-walker), by using the k= option:

```
class MyLexer extends Lexer;
options { k=3; }
...
```

Setting the lookahead depth changes the maximum number of tokens that will be examined to select alternative productions, and test for exit conditions of the EBNF constructs (...)?, (...)+, and (...)*. The lookahead analysis is *linear approximate* (as opposed to full LL(k)). This is a bit involved to explain in detail, but consider this example with k=2:

```
r : ( A B | B A )
  | A A
  ;
```

Full LL(k) analysis would resolve the ambiguity and produce a lookahead test for the first alternate like:

```
if ( (LA(1)==A && LA(2)==B) || (LA(1)==B && LA(2)==A) )
```

However, linear approximate analysis would logically OR the lookahead sets at each depth, resulting in a test like:

```
if ( (LA(1)==A || LA(1)==B) && (LA(2)==A || LA(2)==B) )
```

Which is ambiguous with the second alternate for {A,A}. Because of this, setting the lookahead depth very high tends to yield diminishing returns in most cases, because the lookahead sets at large depths will include almost everything.

importVocab: Initial Grammar Vocabulary

[See the documentation on [vocabularies](#) for more information]

To specify an initial vocabulary (tokens, literals, and token types), use the importVocab grammar option.

```
class MyParser extends Parser;
options {
    importVocab=V;
}
```

ANTLR will look for VTokenTypes.txt in the current directory and preload the token manager for MyParser with the enclosed information.

This option is useful, for example, if you create an external lexer and want to connect it to an ANTLR parser. Conversely, you may create an external parser and wish to use the token set with an ANTLR lexer. Finally, you may find it more convenient to place your grammars in separate files, especially if you have multiple tree-walkers that do not add any literals to the token set.

The vocabulary file has an identifier on the first line that names the token vocabulary that is followed by lines of the form ID=value or "literal"=value. For example:

```
ANTLR // vocabulary name
"header"=3
ACTION=4
COLON=5
SEMI=6
...
```

A file of this form is automatically generated by ANTLR for each grammar.

Note: you must take care to run ANTLR on the vocabulary-generating grammar files **before** you run ANTLR on the vocabulary-consuming grammar files.

exportVocab: Naming Export Vocabulary

[See the documentation on [vocabularies](#) for more information]

The vocabulary of a grammar is the union of the set of tokens provided by an importVocab option and the set of tokens and literals defined in the grammar. ANTLR exports a vocabulary for each grammar whose default name is the same as the grammar. So, the following grammar yields a vocabulary called P:

```
class P extends Parser;
```

```
a : A;
```

ANTLR generates files PTokenTypes.txt and PTokenTypes.java.

You can specify the name of the exported vocabulary with the exportVocab option. The following grammar generates a vocabulary called V not P.

```
class P extends Parser;
options {
    exportVocab=V;
}
a : A;
```

All grammars in the same file with the same vocabulary name contribute to the same vocabulary (and resulting files). If the grammars were in separate files, on the other hand, they would all overwrite the same file. For example, the following parser and lexer grammars both may contribute literals and tokens to the MyTokens vocabulary.

```
class MyParser extends Parser;
options {
    exportVocab=MyTokens;
}
...

class MyLexer extends Lexer;
options {
    exportVocab=MyTokens;
}
...
```

testLiterals: Generate literal-testing code

By default, ANTLR will generate code in all lexers to test each token against the literals table (the table generated for literal strings), and change the token type if it matches the table. However, you may suppress this code generation in the lexer by using a grammar option:

```
class L extends Lexer;
options { testLiterals=false; }
...
```

If you turn this option off for a lexer, you may re-enable it for specific rules. This is useful, for example, if all literals are keywords, which are special cases of ID:

```
ID
options { testLiterals=true; }
    : LETTER (LETTER | DIGIT)*
    ;
```

If you want to test only a portion of a token's text for a match in the literals table, explicitly test the substring within an action using method:

```
public int testLiteralsTable(String text, int ttype) {...}
```

For example, you might want to test the literals table for just the tag word in an HTML word.

defaultErrorHandler: Controlling default exception-handling

By default, ANTLR will generate default exception handling code for a parser or tree-parser rule. The

generated code will catch any parser exceptions, synchronize to the follow set of the rule, and return. This is simple and often useful error-handling scheme, but it is not very sophisticated. Eventually, you will want to install your own exception handlers. ANTLR will automatically turn off generation of default exception handling for rule where an exception handler is specified. You may also explicitly control generation of default exception handling on a per-grammar or per-rule basis. For example, this will turn off default error-handling for the entire grammar, but turn it back on for rule "r":

```
class P extends Parser;
options {defaultErrorHandler=false;}

r
options {defaultErrorHandler=true;}
: A B C;
```

For more information on exception handling in the lexer, go [here](#).

codeGenMakeSwitchThreshold: controlling code generation

ANTLR will optimize lookahead tests by generating a switch statement instead of a series of if/else tests for rules containing a sufficiently large number of alternates whose lookahead is strictly LL(1). The option `codeGenMakeSwitchThreshold` controls this test. You may want to change this to control optimization of the parser. You may also want to disable it entirely for debugging purposes, by setting it to a large number:

```
class P extends Parser;
options { codeGenMakeSwitchThreshold=999; }
...

```

codeGenBitsetTestThreshold: controlling code generation

ANTLR will optimize lookahead tests by generating a bitset test instead of an if statement, for very complex lookahead sets. The option `codeGenBitsetTestThreshold` controls this test. You may want to change this to control optimization of the parser:

```
class P extends Parser;
// make bitset if test involves five or more terms
options { codeGenBitsetTestThreshold=5; }
...

```

You may also want to disable it entirely for debugging purposes, by setting it to a large number:

```
class P extends Parser;
options { codeGenBitsetTestThreshold=999; }
...

```

buildAST: Automatic AST construction

In a Parser, you can tell ANTLR to generate code to construct ASTs corresponding to the structure of the recognized syntax. The option, if set to true, will cause ANTLR to generate AST-building code. With this option set, you can then use all of the [AST-building syntax and support methods](#).

In a Tree-Parser, this option turns on "transform mode", which means an output AST will be generated that is a transformation of the input AST. In a tree-walker, the default action of `buildAST` is to generate a copy of the portion of the input AST that is walked. Tree-transformation is almost identical to building an AST in a Parser, except that the input is an AST, not a stream of tokens.

ASTLabelType: Setting label type

When you must define your own AST node type, your actions within the grammar will require lots of downcasting from AST (the default type of any user-defined label) to your tree node type; e.g.,

```
decl : d:ID {MyAST t=(MyAST)#d;}
      ;
```

This makes your code a pain to type in and hard to read. To avoid this, use the grammar option `ASTLabelType` to have ANTLR automatically do casts and define labels of the appropriate type.

```
class ExprParser extends Parser;

options {
    buildAST=true;
    ASTLabelType = "MyAST";
}

expr : a:term ;
```

The type of `#a` within an action is `MyAST` not `AST`.

charVocabulary: Setting the lexer character vocabulary

ANTLR processes Unicode. Because of this this, ANTLR cannot make any assumptions about the character set in use, else it would wind up generating huge lexers. Instead ANTLR assumes that the character literals, string literals, and character ranges used in the lexer constitute the entire character set of interest. For example, in this lexer:

```
class L extends Lexer;
A : 'a';
B : 'b';
DIGIT : '0' .. '9';
```

The implied character set is { 'a', 'b', '0', '1', '2', '3', '4', '5', '6', '7', '8', '9' }. This can produce unexpected results if you assume that the normal ASCII character set is always used. For example, in:

```
class L extends Lexer;
A : 'a';
B : 'b';
DIGIT : '0' .. '9';
STRING: '"' (~'"")* '"';
```

The lexer rule `STRING` will only match strings containing 'a', 'b' and the digits, which is usually not what you want. To control the character set used by the lexer, use the `charVocabulary` option. This example will use a general eight-bit character set.

```
class L extends Lexer;
options { charVocabulary = '\3'..'377'; }
...
```

This example uses the ASCII character set in conjunction with some values from the extended Unicode character set:

```
class L extends Lexer;
options {
    charVocabulary = '\3'..'377' | '\u1000'..'u1fff';
}
...
```

warnWhenFollowAmbig

[Warning: you should know what you are doing before you use this option. I deliberately made it a pain to shut warnings off (rather than a single character operator) so you would not just start turning off all the warnings. I thought for long time before implementing this exact mechanism. I recommend a comment in front of any use of this option that explains why it is ok to hush the warning.]

This subrule option is true by default and controls the generation of nondeterminism (ambiguity) warnings when comparing the FOLLOW lookahead sets for any subrule with an empty alternative and any closure subrule such as `(..)+` and `(...)*`. For example, the following simple rule has a nondeterministic subrule, which arises from a language ambiguity that you could attach an ELSE clause to the most recent IF **or** to an outer IF because the construct can nest.

```
stat      :      "if" expr "then" stat ("else" stat)?
          |      ID ASSIGN expr SEMI
          ;
```

Because the language is ambiguous, the context-free grammar must be ambiguous and the resulting parser nondeterministic (in theory). However, being the practical language folks that we are, we all know you can trivially solve this problem by having ANTLR resolve conflicts by consuming input as soon as possible; I have yet to see a case where this was the wrong thing to do, by the way. This option, when set to false, merely informs ANTLR that it has made the correct assumption and can shut off an ambiguity related to this subrule and an empty alternative or exit path. Here is a version of the rule that does not yield a warning message:

```
stat      :      "if" expr "then" stat
          (
            // standard if-then-else ambig
            options {
              warnWhenFollowAmbig=false;
            }
            :      "else" stat
          )?
          |      ID ASSIGN expr SEMI
          ;
```

One important note: This option does not affect non-empty alternatives. For example, you will still get a warning for the following subrule between alts 1 and 3 (upon lookahead A):

```
(
  options {
    warnWhenFollowAmbig=false;
  }
  :      A
  |      B
  |      A
)
```

Further, this option is insensitive to lookahead. Only completely empty alternatives count as candidate alternatives for hushing warnings. So, at $k=2$, just because ANTLR can see past alternatives with single tokens, you still can get warnings.

Command Line Options

<code>-o outputDir</code>	specify output directory where all output generated.
---------------------------	--

<code>-glib supergrammarFile</code>	Specify a file with a supergrammar for the generated file.
<code>-debug</code>	launch the ParseView debugger upon parser invocation. Unless you have downloaded and unzipped the debugger over the top of the standard ANTLR distribution, the code emanating from ANTLR with this option will not compile (likewise for Swing).
<code>-html</code>	generate a HTML file from your grammar without actions and so on. This is only a prototype , but seems to do something useful. It only works for parsers, not lexers or tree parsers.
<code>-docbook</code>	generate a docbook SGML file from your grammar without actions and so on. This is only a prototype , but seems to do something useful. It only works for parsers, not lexers or tree parsers.
<code>-diagnostic</code>	generate a text file from your grammar with a lot of debugging info.
<code>-trace</code>	have all rules call traceIn/traceOut.
<code>-traceParser</code>	have parser rules call traceIn/traceOut.
<code>-traceLexer</code>	have lexer rules call traceIn/traceOut.
<code>-traceTreeParser</code>	have tree walker rules call traceIn/traceOut.
<code>-h -help --help</code>	help message.

Version: \$Id: //depot/code/org.antlr/release/antlr-2.7.3/doc/options.html#1 \$